



COLLARS and WASHERS

HEAVY TURNED WASHERS	page 4
TURNED TAPER WASHERS	5
TURNED WASHERS FOR SWIVEL HEADS	5
COLLARS IN COMPLIANCE WITH DIN 705	6
CLAMPING COLLARS FORM C-AB	7
CLAMPING COLLARS WITH OPEN RING	8



CLAMPING COLLARS

CLAMPING COLLARS

PHOSPHATED

GALVANISED

INOX

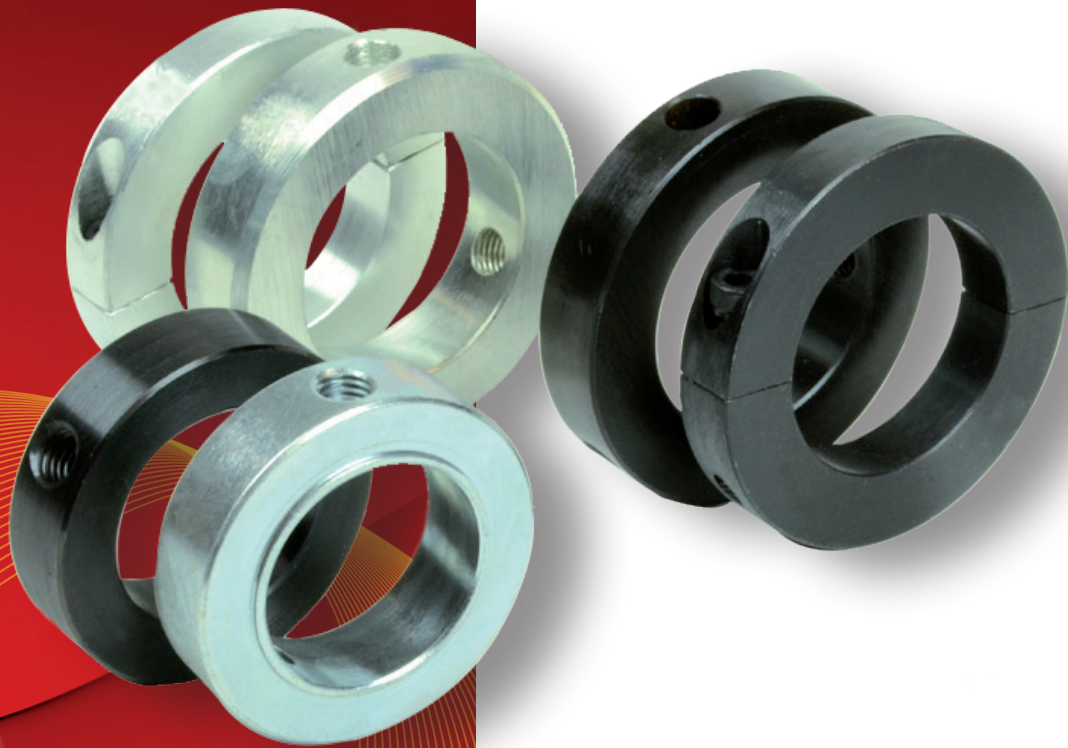

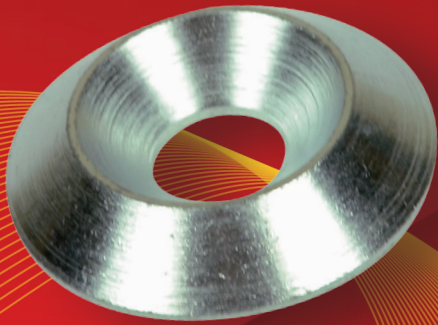
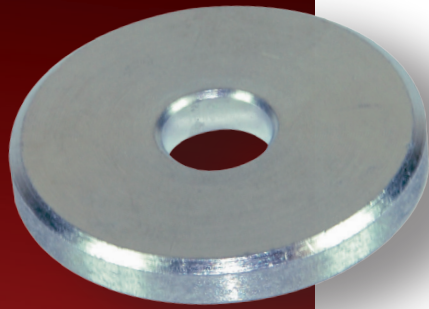

TURNUED WASHERS
PHOSPHATED
GALVANISED



C-RGS

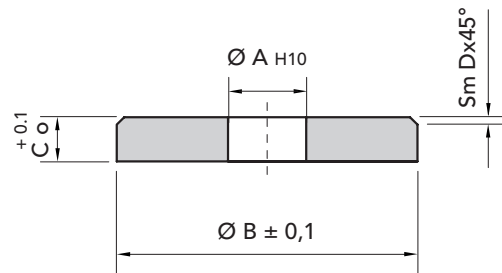

TYPE	PHOSPHATED PART NUMBER	GALVANISED PART NUMBER	$\varnothing A$	$\varnothing B$	C	D	PACKAGES FROM	WEIGHT PACKAGE kg
C-RGS 3-10	26100310	26200310	3,2	10	2	0,5	50	0,10
C-RGS 4-10	26100410	26200310	4,2	10	2	0,5	50	0,10
C-RGS 4-15	26100415	26200415	4,2	15	3	0,5	50	0,15
C-RGS 5-15	26100515	26200515	5,2	15	3	0,5	50	0,15
C-RGS 5-20	26100520	26200520	5,2	20	3	0,5	50	0,45
C-RGS 5-25	26100525	26200525	5,2	25	4	1	50	0,70
C-RGS 5-30	26100530	26200530	5,2	30	4	1	50	1,35
C-RGS 6-15	26100615	26200615	6,2	15	3	0,5	50	0,12
C-RGS 6-20	26100620	26200620	6,2	20	3	0,5	50	0,40
C-RGS 6-25	26100625	26200625	6,2	25	4	1	50	0,80
C-RGS 6-30	26100630	26200630	6,2	30	4	1	50	1,05
C-RGS 6-35	26100635	26200635	6,2	35	5	1	50	1,85
C-RGS 6-40	26100640	26200640	6,5	40	5	1	50	2,35
C-RGS 8-20	26100820	26200820	8,5	20	4	0,5	25	0,35
C-RGS 8-25	26100825	26200825	8,5	25	4	1	25	0,70
C-RGS 8-30	26100830	26200830	8,5	30	4	1	25	1,00
C-RGS 8-35	26100835	26200835	8,5	35	5	1	25	1,80
C-RGS 8-40	26100840	26200840	8,5	40	5	1	25	2,30
C-RGS 8-45	26100845	26200845	8,5	45	5	2	25	2,90
C-RGS 8-50	26100850	26200850	8,5	50	6	2	25	4,15
C-RGS 10-25	26101025	26201025	10,5	25	4	1	25	2,00
C-RGS 10-35	26101035	26201035	10,5	35	5	1	25	1,60
C-RGS 10-40	26101040	26201040	10,5	40	5	1	25	2,25
C-RGS 10-45	26101045	26201045	10,5	45	5	2	25	2,65
C-RGS 10-50	26101050	26201050	10,5	50	6	2	25	4,10
C-RGS 12-50	26101250	26201250	12,5	50	6	2	25	4,60

MATERIAL **C 45 UNI 7845**
PHOSPHATED
GALVANISED

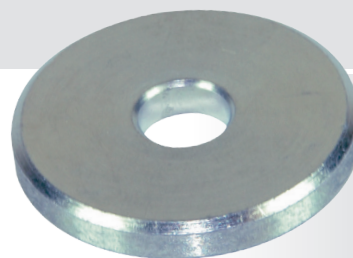

CAD drawings available on our site
www.chiaravalli.com

Quantity, availability and prices
 on B2B Chiaravalli



TURNED TAPER WASHERS

C-RC

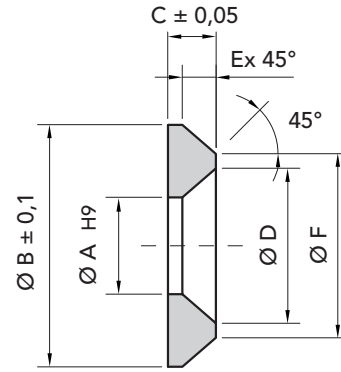

TYPE	PHOSPHATED P. NUMBER	GALVANISED P. NUMBER	Ø A	Ø B	C	Ø D	E	Ø F	PACKAGES	WEIGHT
									FROM	PACKAGE
C-RC 4	26300004	26400004	4,1	13	3	8	2,1x45°	8,8	50	0,12
C-RC 5	26300005	26400005	5,2	16	3,5	10	2,6x45°	10,8	50	0,15
C-RC 6	26300006	26400006	6,5	18	3,5	12	2,1x45°	13,8	50	0,24
C-RC 8	26300008	26400008	8,5	25	5	16,5	3,5x45°	18	50	0,36
C-RC 10	26300010	26400010	10,5	33	7	20,5	6x45°	21	50	0,75
C-RC 12	26300012	26400012	12,5	40	8	24,5	7x45°	26	50	1,50



TURNED TAPER WASHERS and TURNED WASHERS FOR SWIVEL HEADS



TURNED WASHERS FOR SWIVEL HEADS

C-RS

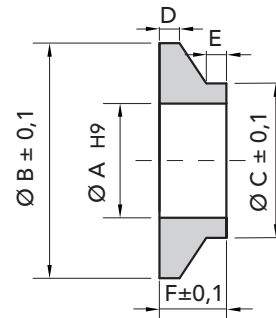

TYPE	PHOSPHATED P. NUMBER	GALVANISED P. NUMBER	Ø A	Ø B	C	Ø D	E	Ø F	PACKAGES	WEIGHT
									FROM	PACKAGE
C-RS 6	26500006	26600006	6,5	15	9	1,5	1	4	50	0,15
C-RS 8	26500008	26600008	8,5	22	12	1,5	2	6,5	50	0,27
C-RS 10	26500010	26600010	10,5	22	14	1,5	3	6,5	50	0,40



MATERIAL C 45 UNI 7845
PHOSPHATED
GALVANISED

CAD drawings available on our site
www.chiaravalli.com

Quantity, availability and prices
on B2B Chiaravalli



SPECIAL

COMPONENTS MANUFACTURING

We produce high precision Gears and Special Mechanical Components.

A large and varied range of modern CNC machine tools assures large capacity production at high quality level.

Chiaravalli Group SpA co-workers, highly skilful and motivated by a great spirit of belonging to the company,

operate using the most modern CAE and CAD-CAM technologies. The production is certified and assured using three-dimensional high precision measuring machines.

Chiaravalli Group SpA your technological partner for high quality production.

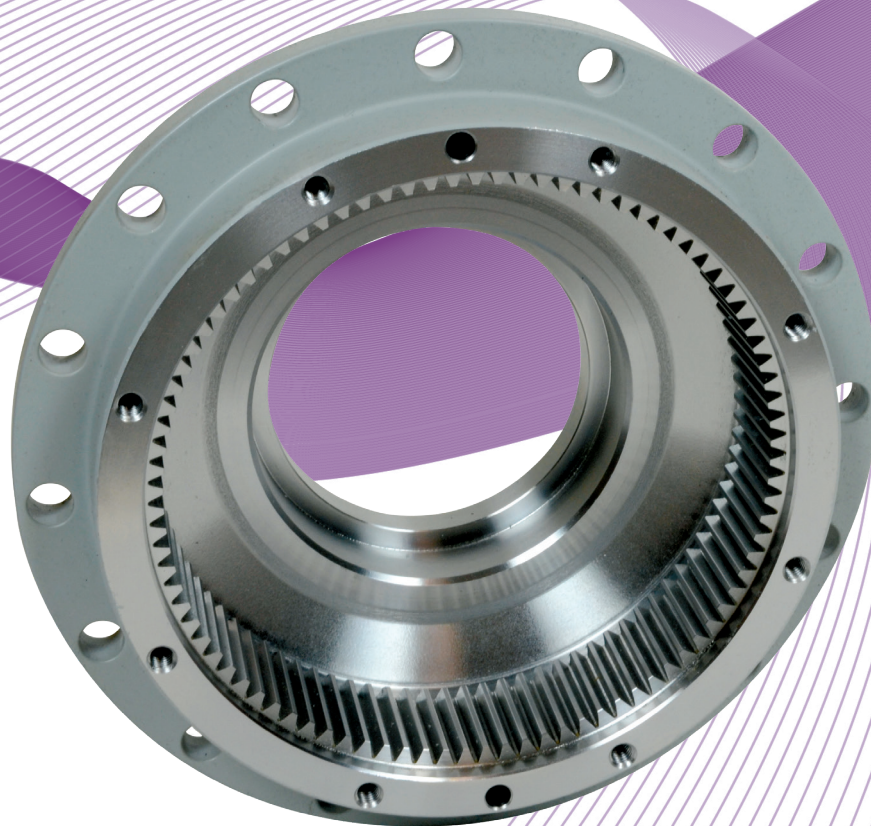



WORM SCREW

JACKS

The new line of Worm Screw Jacks named CHT (Chiaravalli High Tech) integrates and completes our range of Mechanical Transmission products.

This new line of products is manufactured using high quality materials, manufactured with absolute precision, making use of the modern machinery fleet of the companies belonging to Chiaravalli Group SpA.

The basic elements that make up the final product "Screw Jack" are made in large series, rigorously

checked and put in stock.

Special virtual software developed by Chiaravalli Group SpA enables our customers to first view the various elements of the required screw jack and then, in the second phase, to order it with absolute precision and confidence.

Chiaravalli Group SpA is engaged to ensure the delivery of this product in very short time, with quality and precision.

