



PILLOW BLOCKS FSB[®] BRAND

MONOBLOCK PILLOW BLOCKS RCM[®] BRAND

CAST IRON PILLOW BLOCKS

SERIES: UCP 200	page 4
UCF 200	5
UCFL 200	6
UCFA 200	7
UCT 200	8
UCFC 200	9
UCPA 200	10

PRESSED STEEL HOUSING PILLOW BLOCKS

SERIES: PP 200	11
PF 200	12
PFL 200	13

THERMOPLASTIC PILLOW BLOCKS

SERIES: P 200	14
F 200	15
FL 200	16

BEARINGS

SERIES: UC 200	18
UK 200	19
SB RE-LUBRICATING 200	20
SA RE-LUBRICATING 200	21

INOX BEARINGS

SERIES: SUC 200	23
SSSB RE-LUBRICATING 200	24

BUSHES SERIES H23... AND COVER FOR PILLOW BLOCKS

SEALS

STIFF RADIAL BALL BEARINGS

RCC 2RS	27
RCC ZZ	28

PILLOW BLOCKS

RCM SERIES	page 30
------------	---------

Nominal torque and power rating	33
---------------------------------	----

Diagram for the choice of RCM pillow blocks	34
--	----

RCM SERIES

AS standard shaft	36
-------------------	----

RCM SERIES

AL long shaft	38
---------------	----

RCM SERIES

RCM-AL for cooling fan	40
------------------------	----

NON-ROTATING GROUP

41



CHIARAVALLI GROUP BRAND **FSB**[®]
CAST IRON, PRESSED STEEL HOUSING AND THERMOPLASTIC **PILLOW BLOCKS**

SERIES CAST IRON, PRESSED STEEL HOUSING AND THERMOPLASTIC **PILLOW BLOCKS BRAND FSB**[®]





CHIARAVALLI GROUP BRAND **FSB**[®]
 CAST IRON, PRESSED STEEL HOUSING AND THERMOPLASTIC PILLOW BLOCKS



UCP 200



UCFC 200



P 200

THERMOPLASTIC



UCF 200



UCPA 200



F 200

THERMOPLASTIC



UCFL 200



PP 200



FL 200

THERMOPLASTIC



UCFA 200



PF 200



SA 200

SB 200

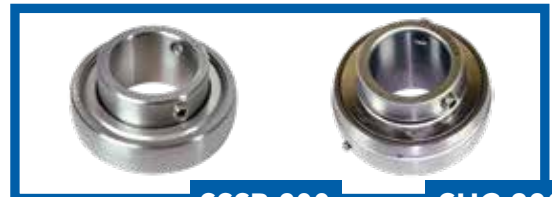

SSSB 200

SUC 200



UCT 200



PFL 200

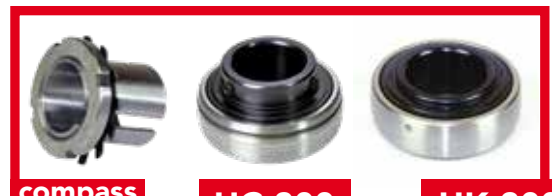

**compass
H23**

UC 200

UK 200

UCP 200

FROM 202 TO 211
 SUITABLE FOR COVER ASSEMBLY

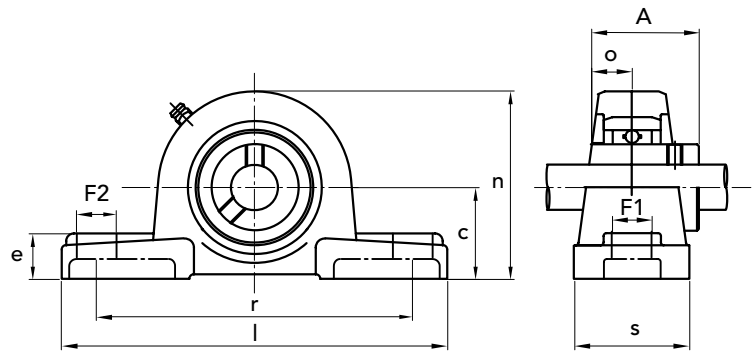

UCP	PART NUMBER	shaft hole Ø mm	DIMENSIONS mm										bearing No.	bolt dimensions mm	housing No.	weight kg
			c	l	r	s	F1	F2	e	n	A	o				
202	93100202	15	30,2	127	95	38	13	16	14	62	31	12,7	UC 202	M10	P202	0,63
203	93100203	17	30,2	127	95	38	13	16	14	62	31	12,7	UC 203	M10	P203	0,62
204	93100204	20	33,3	127	95	38	13	16	14	65	31	12,7	UC 204	M10	P204	0,70
205	93100205	25	36,5	140	105	38	13	16	15	71	34	14,3	UC 205	M10	P205	0,81
206	93100206	30	42,9	165	121	48	17	20	17	83	38,1	15,9	UC 206	M14	P206	1,30
207	93100207	35	47,6	167	127	48	17	20	18	93	42,9	17,5	UC 207	M14	P207	1,60
208	93100208	40	49,2	184	137	54	17	20	18	98	49,2	19	UC 208	M14	P208	2,00
209	93100209	45	54	190	146	54	17	20	20	106	49,2	19	UC 209	M14	P209	2,30
210	93100210	50	57,2	206	159	60	20	23	21	114	51,6	19	UC 210	M16	P210	2,90
211	93100211	55	63,5	219	171	60	20	23	23	126	55,6	22,2	UC 211	M16	P211	3,70
212	93100212	60	69,8	241	184	70	20	23	25	138	65,1	25,4	UC 212	M16	P212	4,90
213	93100213	65	76,2	265	203	70	25	28	27	151	65,1	25,4	UC 213	M20	P213	5,90
214	93100214	70	79,4	266	210	72	25	28	27	157	74,6	30,2	UC 214	M20	P214	6,60
215	93100215	75	82,6	275	217	74	25	28	28	163	77,8	33,3	UC 215	M20	P215	7,30
216	93100216	80	88,9	292	232	78	25	28	30	175	82,6	33,3	UC 216	M20	P216	10,0
217	93100217	85	95,2	310	247	83	25	28	32	187	85,7	34,1	UC 217	M20	P217	12,2
218	93100218	90	101,6	327	262	88	27	30	33	200	96	39,7	UC 218	M22	P218	14,7

CAD drawings available on our site
www.chiaravalli.com

Quantity, availability and prices
 on B2B Chiaravalli

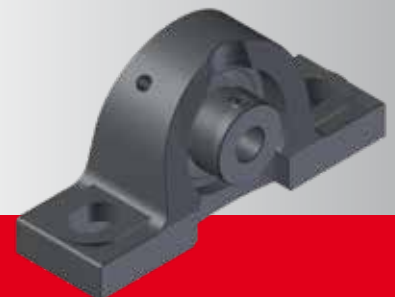



UCF 200

FROM 202 TO 211
SUITABLE FOR COVER ASSEMBLY

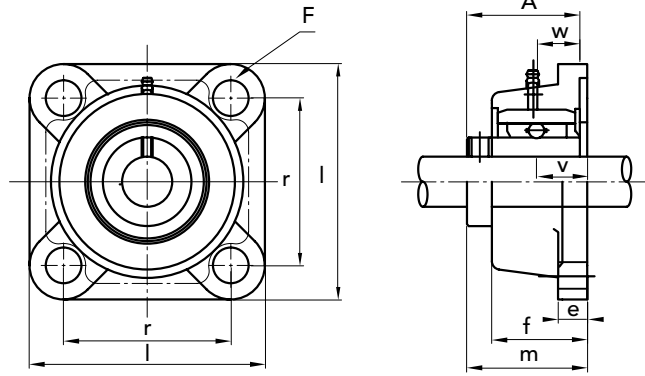

CAST IRON PILLOW BLOCKS SERIES UCF 200

UCF	PART NUMBER	shaft hole Ø mm	DIMENSIONS mm									bearing dimensions			weight kg	
			l	r	v	e	f	F	m	A	w	No.	mm	No.		
202	93200202	15	86	64	15	11	25,5	12	33,3	31	12,7	UC 202	M10	P202	0,62	
203	93200203	17	86	64	15	11	25,5	12	33,3	31	12,7	UC 203	M10	P203	0,61	
204	93200204	20	86	64	15	11	25,5	12	33,3	31	12,7	UC 204	M10	P204	0,61	
205	93200205	25	95	70	16	13	27	12	35,7	34	14,3	UC 205	M10	P205	0,80	
206	93200206	30	108	83	18	13	31	12	40,2	38,1	15,9	UC 206	M10	P206	1,00	
207	93200207	35	117	92	19	15	34	14	44,4	42,9	17,5	UC 207	M12	P207	1,40	
208	93200208	40	130	102	21	15	36	16	51,2	49,2	19	UC 208	M14	P208	1,80	
209	93200209	45	137	105	22	16	38	16	52,2	49,2	19	UC 209	M14	P209	2,20	
210	93200210	50	143	111	22	16	40	16	54,6	51,6	19	UC 210	M14	P210	2,40	
211	93200211	55	162	130	25	18	43	19	58,4	55,6	22,2	UC 211	M16	P211	3,50	
212	93200212	60	175	143	29	18	48	19	68,7	65,1	25,4	UC 212	M16	P212	4,20	
213	93200213	65	187	149	30	22	50	19	69,7	65,1	25,4	UC 213	M16	P213	5,30	
214	93200214	70	193	152	31	22	54	19	75,4	74,6	30,2	UC 214	M16	P214	5,90	
215	93200215	75	200	159	34	22	56	19	78,5	77,8	33,3	UC 215	M16	P215	6,30	
216	93200216	80	208	165	34	22	58	23	83,3	82,6	33,3	UC 216	M20	P216	7,80	
217	93200217	85	220	175	36	24	63	23	87,6	85,7	34,1	UC 217	M20	P217	9,30	
218	93200218	90	235	187	40	24	68	23	96,3	96	39,7	UC 218	M20	P218	11,3	



UCFL 200

FROM 202 TO 211
 SUITABLE FOR COVER ASSEMBLY

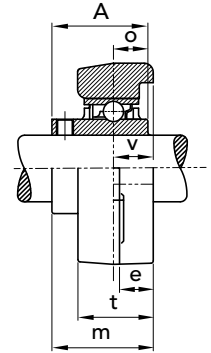
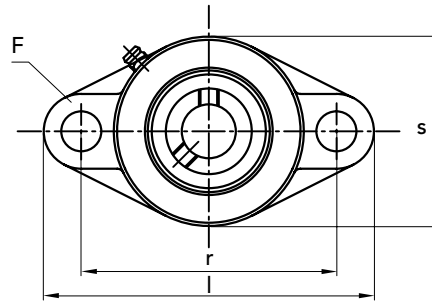

UCFL	PART NUMBER	shaft hole Ø mm	DIMENSIONS mm										bolt			weight kg
			l	r	v	e	t	F	s	m	A	o	bearing No.	dimensions mm	housing No.	
202	93300202	15	113	90	15	11	25,5	12	60	33,3	31	12,7	UC 202	M10	FL202	0,47
203	93300203	17	113	90	15	11	25,5	12	60	33,3	31	12,7	UC 203	M10	FL203	0,45
204	93300204	20	113	90	15	11	25,5	12	60	33,3	31	12,7	UC 204	M10	FL204	0,43
205	93300205	25	130	99	16	13	27	16	68	35,7	34	14,3	UC 205	M14	FL205	0,61
206	93300206	30	148	117	18	13	31	16	80	40,2	38,1	15,9	UC 206	M14	FL206	0,86
207	93300207	35	161	130	19	15	34	16	90	44,4	42,9	17,5	UC 207	M14	FL207	1,20
208	93300208	40	175	144	21	15	36	16	100	51,2	49,2	19	UC 208	M14	FL208	1,48
209	93300209	45	188	148	22	16	38	19	108	52,2	49,2	19	UC 209	M16	FL209	1,84
210	93300210	50	197	157	22	16	40	19	115	54,6	51,6	19	UC 210	M16	FL210	2,14
211	93300211	55	224	184	25	18	43	19	130	58,4	55,6	22,2	UC 211	M16	FL211	2,98
212	93300212	60	250	202	29	18	48	23	140	68,7	65,1	25,4	UC 212	M20	FL212	3,90
213	93300213	65	258	210	30	22	50	23	155	69,7	65,1	25,4	UC 213	M20	FL213	4,77
214	93300214	70	265	216	31	22	54	23	160	75,4	74,6	30,2	UC 214	M20	FL214	5,22
215	93300215	75	275	225	34	22	56	23	165	78,5	77,8	33,3	UC 215	M20	FL215	5,66
216	93300216	80	290	233	34	22	58	25	180	83,3	82,6	33,3	UC 216	M22	FL216	7,13

CAD drawings available on our site
www.chiaravalli.com

Quantity, availability and prices
 on B2B Chiaravalli





UCFA 200

FROM 202 TO 211
 SUITABLE FOR COVER ASSEMBLY

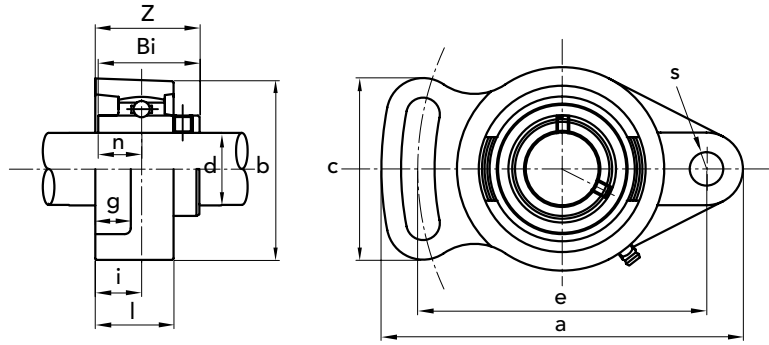

CAST IRON PILLOW BLOCKS SERIES UCFA 200

UCFA	PART NUMBER	shaft hole Ø mm	DIMENSIONS mm											bolt			weight kg
			a	e	i	g	l	s	b	z	c	Bi	n	bearing No.	dimension mm	housing No.	
202	93310202	15	98	78	15	11	25,5	10	60	33,3	50	31,1	12,7	UC 202	M8	FA202	0,47
203	93310203	17	98	78	15	11	25,5	10	60	33,3	50	31,1	12,7	UC 203	M8	FA203	0,47
204	93310204	20	98	78	15	11	25,5	10	60	33,3	50	31,1	12,7	UC 204	M8	FA204	0,47
205	93310205	25	124	98	16	13	27	12	70	35,7	65	34	14,3	UC 205	M10	FA205	0,68
206	93310206	30	141	117	18	13	31	12	83	40,2	72	38,1	15,9	UC 206	M10	FA206	1,00
207	93310207	35	155	130	19	14	34	14	96	44,4	82	42,9	17,5	UC 207	M12	FA207	1,50
208	93310208	40	171	144	21	14	38	14	105	51,2	87	49,2	19	UC 208	M12	FA208	1,90

CAD drawings available on our site
www.chiaravalli.com

Quantity, availability and prices
 on B2B Chiaravalli



UCT 200

FROM 202 TO 211
 SUITABLE FOR COVER ASSEMBLY

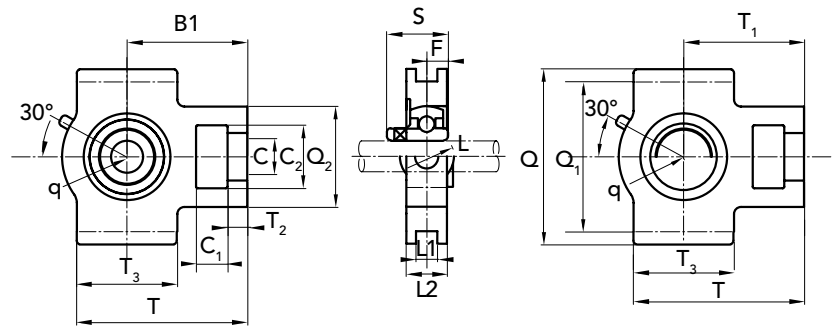

UCT	PART NUMBER	shaft hole Ø mm	DIMENSIONS mm																	weight kg
			C ₁	T ₂	Q ₂	C ₂	C	T ₃	L ₁	Q ₁	Q	T	L ₂	L	q	T ₁	S	F		
202	93400202	15	16	12	51	32	19	51	12	76	89	94	21	32	33	61	31	12,7	0,80	
203	93400203	17	16	12	51	32	19	51	12	76	89	94	21	32	33	61	31	12,7	0,80	
204	93400204	20	16	12	51	32	19	51	12	76	89	94	21	32	33	61	31	12,7	0,80	
205	93400205	25	16	12	51	32	19	51	12	76	89	97	24	32	35	62	34	14,3	0,80	
206	93400206	30	16	12	56	37	22	57	12	89	102	113	28	37	43	70	38,1	15,9	1,15	
207	93400207	35	16	15	64	37	22	64	12	89	102	129	30	37	51	78	42,9	17,5	1,15	
208	93400208	40	19	18	83	49	29	83	16	102	114	144	33	49	56	88	49,2	19	1,15	
209	93400209	45	19	18	83	49	29	83	16	102	117	145	35	49	57	88	49,2	19	1,28	
210	93400210	50	19	18	83	49	29	86	16	102	117	151	37	49	59	92	51,6	19	1,28	
211	93400211	55	25	21	102	64	35	95	22	130	146	171	38	64	65	106	55,6	22,2	1,28	
212	93400212	60	32	21	102	64	35	102	22	130	146	194	42	64	75	119	65,1	25,4	4,58	
213	93400213	65	32	21	111	70	41	121	26	151	167	224	44	70	80	137	65,1	25,4	6,65	
214	93400214	70	32	21	111	70	41	121	26	151	167	224	46	70	80	137	74,6	30,2	6,80	

CAD drawings available on our site
www.chiaravalli.com

Quantity, availability and prices
 on B2B Chiaravalli

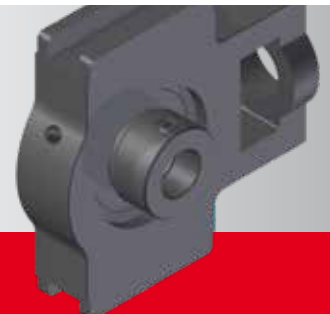



UCFC 200

FROM 202 TO 211
 SUITABLE FOR COVER ASSEMBLY

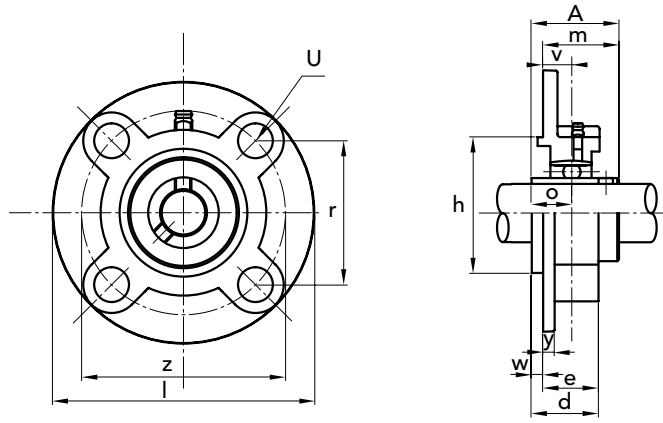

CAST IRON PILLOW BLOCKS SERIES UCFC 200

UCFC	PART NUMBER	shaft hole Ø mm	DIMENSIONS mm													bearing No.	dimensions housing mm	housing No.	weight kg
			l	z	r	v	d	U	y	w	e	h	m	A	o				
202	93500202	15	100	78	55,1	10	25,5	12	5	7	20,5	62	28,3	31	12,7	UC 202	M10	FC202	0,76
203	93500203	17	100	78	55,1	10	25,5	12	5	7	20,5	62	28,3	31	12,7	UC 203	M10	FC203	0,76
204	93500204	20	100	78	55,1	10	25,5	12	5	7	20,5	62	28,3	31	12,7	UC 204	M10	FC204	0,76
205	93500205	25	115	90	63,6	10	27	12	6	7	21	70	29,7	34	14,3	UC 205	M10	FC205	0,96
206	93500206	30	125	100	70,7	10	31	12	8	8	23	80	32,2	38,1	15,9	UC 206	M10	FC206	1,30
207	93500207	35	135	110	77,8	11	34	14	8	9	26	90	36,4	42,9	17,5	UC 207	M12	FC207	1,70
208	93500208	40	145	120	84,8	11	36	14	10	9	26	100	41,2	49,2	19	UC 208	M12	FC208	2,00
209	93500209	45	160	132	93,3	10	38	16	12	14	26	105	40,2	49,2	19	UC 209	M14	FC209	2,70
210	93500210	50	165	138	97,6	10	40	16	12	14	28	110	42,6	51,6	19	UC 210	M14	FC210	2,90
211	93500211	55	185	150	106,1	13	43	19	12	15	31	125	46,4	55,6	22,2	UC 211	M16	FC211	4,30
212	93500212	60	195	160	113,1	17	48	19	12	15	36	135	56,7	65,1	25,4	UC 212	M16	FC212	5,00
213	93500213	65	205	170	120,2	16	50	19	14	15	36	145	55,7	65,1	25,4	UC 213	M16	FC213	5,70
214	93500214	70	215	177	125,1	17	54	19	14	18	40	150	61,4	74,6	30,2	UC 214	M16	FC214	6,80

CAD drawings available on our site
www.chiaravalli.com

Quantity, availability and prices
 on B2B Chiaravalli

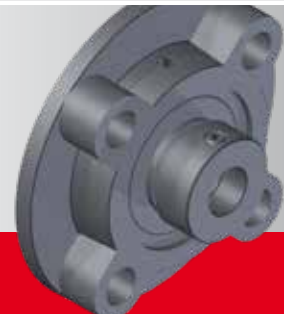

UCPA 200

FROM 202 TO 211
 SUITABLE FOR COVER ASSEMBLY

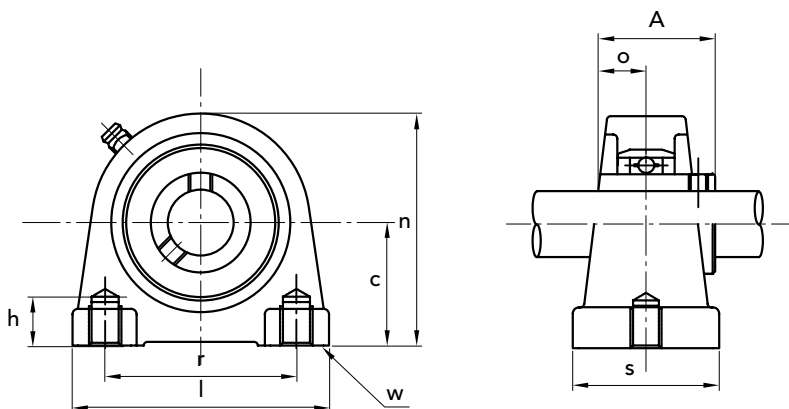

UCPA	PART NUMBER	shaft hole Ø mm	DIMENSIONS mm										bearing No.	housing No.	weight kg
			c	l	r	s	w	n	A	o	h				
202	93600202	15	30,2	76	52	40	M10x1,5	62	31	12,7	13	UC 202	PA202	0,63	
203	93600203	17	30,2	76	52	40	M10x1,5	62	31	12,7	13	UC 203	PA203	0,62	
204	93600204	20	30,2	76	52	40	M10x1,5	62	31	12,7	13	UC 204	PA204	0,64	
205	93600205	25	36,5	84	56	45	M10x1,5	72	34	14,3	15	UC 205	PA205	0,81	
206	93600206	30	42,9	94	66	50	M14x2	84	38,1	15,9	18	UC 206	PA206	1,20	
207	93600207	35	47,6	110	80	55	M14x2	95	42,9	17,5	20	UC 207	PA207	1,65	
208	93600208	40	49,2	116	84	58	M14x2	100	49,2	19	20	UC 208	PA208	2,00	
209	93600209	45	54,2	120	90	60	M14x2	108	49,2	19	25	UC 209	PA209	2,30	
210	93600210	50	57,2	130	94	64	M16x2	116	51,6	19	25	UC 210	PA210	2,90	
211	93600211	55	63,5	140	104	66	M16x2	125	55,6	22,2	25	UC 211	PA211	3,16	
212	93600212	60	69,9	150	114	68	M16x2	138	65,1	25,4	25	UC 212	PA212	4,15	
213	93600213	65	76,2	160	124	70	M16x2	150	65,1	25,4	25	UC 213	PA213	5,09	

CAD drawings available on our site
www.chiaravalli.com

Quantity, availability and prices
 on B2B Chiaravalli

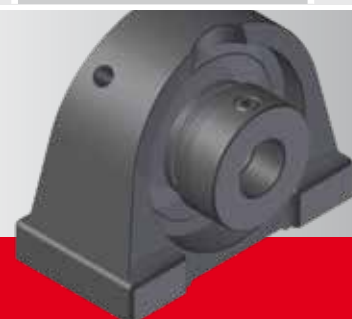



PP 200

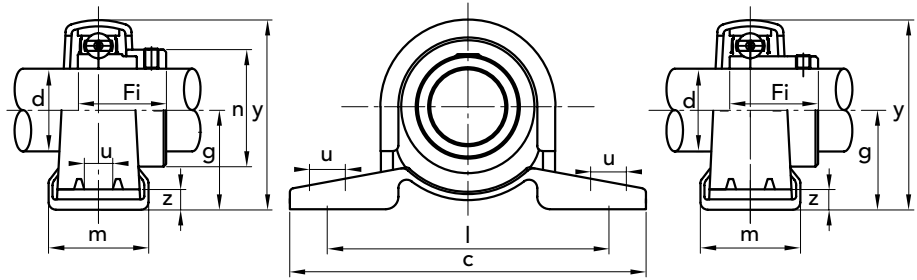

PRESSED STEEL HOUSING PILLOW BLOCKS SERIES PP 200

PP	PART NUMBER	shaft hole Ø mm	DIMENSIONS mm							bolt c mm	SAPP				SBPP			housing No.
			g	c	l	m	u	z	y		Fi	n	No.	kg	Fi	No.	Kg	
201	93700201	12	22,2	86	68	25	9,5	3	43,8	M8	28,6	28,6	SA201	0,19	22	SB201	0,16	PP201
202	93700202	15	22,2	86	68	25	9,5	3	43,8	M8	28,6	28,6	SA202	0,19	22	SB202	0,16	PP202
203	93700203	17	22,2	86	68	25	9,5	3	43,8	M8	28,6	28,6	SA203	0,19	22	SB203	0,16	PP203
204	93700204	20	25,4	98	76	32	9,5	3	50,5	M8	31	33,3	SA204	0,23	25	SB204	0,23	PP204
205	93700205	25	28,6	108	86	32	11,5	4	56,6	M10	31	38,1	SA205	0,32	27	SB205	0,28	PP205
206	93700206	30	33,3	117	95	38	11,5	4	66,3	M10	35,7	44,5	SA206	0,41	30	SB206	0,38	PP206
207	93700207	35	39,7	129	106	42	11,5	5	77,7	M10	38,9	55,6	SA207	0,50	32	SB207	0,47	PP207

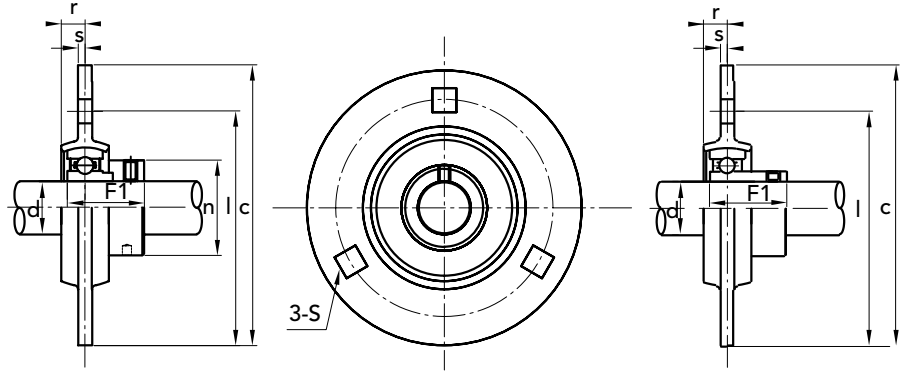

PF 200

SAPF
SBPF

PF	PART NUMBER	shaft hole Ø mm	DIMENSIONS mm					bolt dimensions mm	bearing weight			bearing weight housing				
			c	l	r	s	S		Fi	n	No.	kg	Fi	No.	Kg	No.
201	93800201	12	81	63,5	7	2	7,1	M6	28,6	28,6	SA201	0,30	22	SB201	0,27	PF201
202	93800202	15	81	63,5	7	2	7,1	M6	28,6	28,6	SA202	0,30	22	SB202	0,27	PF202
203	93800203	17	81	63,5	7	2	7,1	M6	28,6	28,6	SA203	0,30	22	SB203	0,27	PF203
204	93800204	20	90	71,5	8	2	9	M8	31	33,3	SA204	0,33	25	SB204	0,33	PF204
205	93800205	25	95	76	9	2	9	M8	31	38,1	SA205	0,42	27	SB205	0,38	PF205
206	93800206	30	113	90,5	9,5	2,6	11	M10	35,7	44,5	SA206	0,65	30	SB206	0,62	PF206
207	93800207	35	122	100	10	2,6	11	M10	38,9	55,6	SA207	0,90	32	SB207	0,82	PF207
208	93800208	40	148	119	11,5	3,5	13,5	M12	43,7	60,3	SA208	1,40	34	SB208	1,3	PF208
209	93800209	45	150	120,5	11,5	3,5	13,5	M12	43,7	63,5	SA209	1,50	41,2	SB209	1,5	PF209

CAD drawings available on our site
www.chiaravalli.com

Quantity, availability and prices
on B2B Chiaravalli





PFL 200

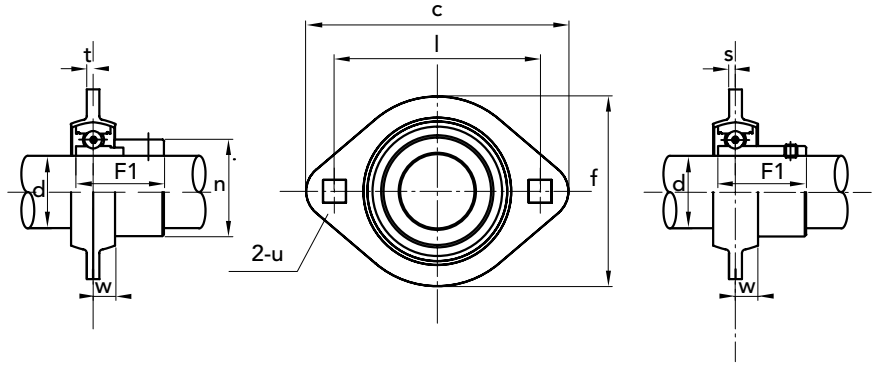

PRESSED STEEL HOUSING PILLOW BLOCKS SERIES PFL 200

PFL	PART NUMBER	shaft hole Ø mm	DIMENSIONS mm							bolt dimensions		SAPFL bearing weight			SBPFL bearing weight			housing No.
			c	l	w	f	s	u	mm	Fi	n	No.	kg	Fi	No.	Kg		
201	93900201	12	81	63,5	7	59	2	7,1	M6	28,6	28,6	SA201	0,22	22	SB201	0,19	PFL201	
202	93900202	15	81	63,5	7	59	2	7,1	M6	28,6	28,6	SA202	0,22	22	SB202	0,19	PFL202	
203	93900203	17	81	63,5	7	59	2	7,1	M6	28,6	28,6	SA203	0,22	22	SB203	0,19	PFL203	
204	93900204	20	90	71,5	8	67	2	9	M8	31	33,3	SA204	0,24	25	SB204	0,24	PFL204	
205	93900205	25	95	76	9	71	2	9	M8	31	38,1	SA205	0,32	27	SB205	0,28	PFL205	
206	93900206	30	113	90,5	9,5	84	2,6	11	M10	35,7	44,5	SA206	0,41	30	SB206	0,38	PFL206	
207	93900207	35	122	100	10	94	2,6	11	M10	38,9	55,6	SA207	0,50	32	SB207	0,42	PFL207	
208	93900208	40	148	119	11	106	3,5	13,5	M12	43,7	60,3	SA208	0,67	34	SB208	0,60	PFL208	

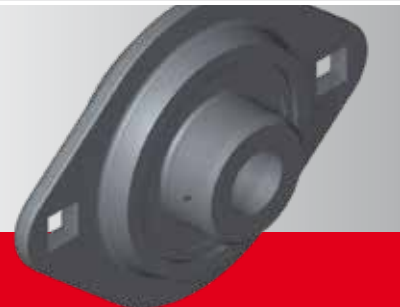

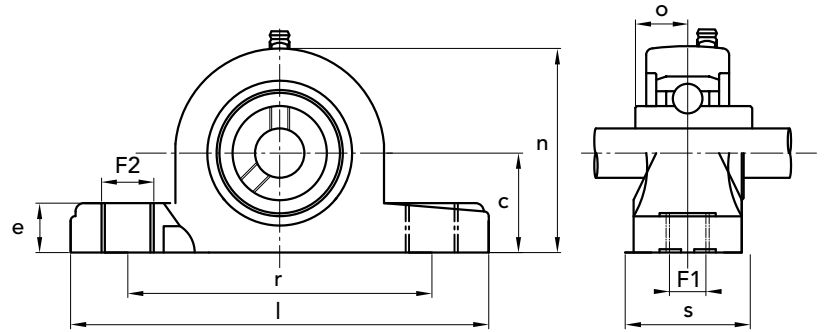
P 200

P	PART NUMBER	shaft hole Ø mm	DIMENSIONS mm									bearing mm	housing No.	weight kg
			c	l	r	s	F1	F2	e	n	o			
203	93191203	17	33,3	127	95	38	11	14	14,2	65,5	12,7	M10	P203	0,13
204	93191204	20	33,3	127	95	38	11	14	14,2	65,5	12,7	M10	P204	0,13
205	93191205	25	36,5	140,5	105	38	11	14	14,5	71	14,3	M10	P205	0,14
206	93191206	30	42,9	163	119	46	14	18	17,8	84	15,9	M12	P206	0,25
207	93191207	35	47,6	168	127	48	14	18	18	94,5	17,5	M12	P207	0,27
208	93191208	40	49,2	184	137	54	14	18	19,5	99	19	M12	P208	0,32
209	93191209	45	54	192	146	54	17	20	23	1,6	19	M16	P209	0,37
210	93191210	50	57,2	206	159	60	17	20	23	114	19	M16	P210	0,44

SUCP	PART NUMBER	shaft hole Ø mm	DIMENSIONS mm									bearing	housing No.	weight kg
			c	l	r	s	F1	F2	e	n	o			
205	93192205	25	36,5	140,5	105	38	11	14	14,5	71	14,3	SUC 205	P205	0,33
206	93192206	30	42,9	163	119	46	14	18	17,8	84	15,9	SUC 206	P206	0,56
207	93192207	35	47,6	168	127	48	14	18	18	94,5	17,5	SUC 207	P207	0,73
208	93192208	40	49,2	184	137	54	14	18	19,5	99	19	SUC 208	P208	0,93

CAD drawings available on our site
www.chiaravalli.com

Quantity, availability and prices
 on B2B Chiaravalli





F 200

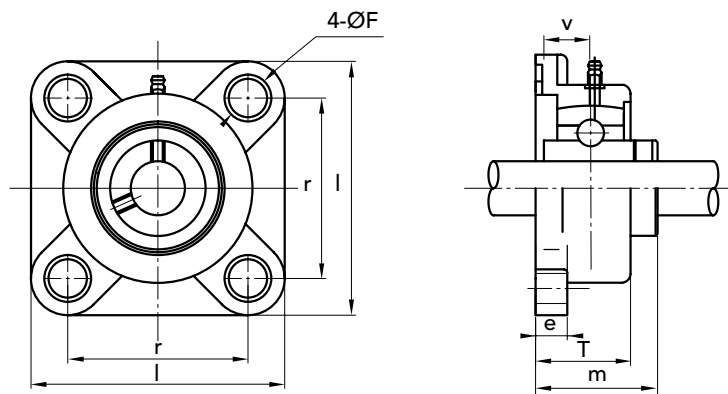

F	PART NUMBER	shaft hole Ø mm	DIMENSIONS mm							bearing mm	housing No.	weight kg
			l	r	e	T	F	m	v			
203	93291203	17	88	63,5	14,4	27,8	11	36,3	18	M10	F203	0,13
204	93291204	20	88	63,5	14,4	27,8	11	36,3	18	M10	F204	0,13
205	93291205	25	95	70	14	28	11	36,7	17	M10	F205	0,14
206	93291206	30	107	83	14,3	31,5	11	41,4	19,2	M10	F206	0,21
207	93291207	35	118	92	15,5	34,8	13	45,9	21,5	M12	F207	0,26
208	93291208	40	130	102	17	37,5	14	53,2	23	M16	F208	0,34
209	93291209	45	137	105	19	41	17	54,2	24	M16	F209	0,41
210	93291210	50	143	111	21	43	17	57,6	25	M16	F210	0,44

SUCFL	PART NUMBER	shaft hole Ø mm	DIMENSIONS mm							bearing	housing No.	weight kg
			l	r	e	T	F	m	v			
204	93292204	20	88	63,5	14,4	27,8	11	36,3	18	SUC 204	F204	0,28
205	93292205	25	95	70	14	28	11	36,7	17	SUC 205	F205	0,33
206	93292206	30	107	83	14,3	31,5	11	41,4	19,2	SUC 206	F206	0,52
208	93292208	40	130	102	17	37,5	14	53,2	23	SUC 208	F208	0,95L

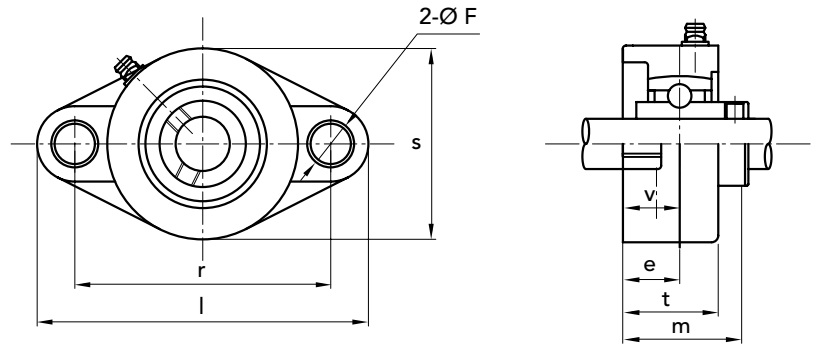

FL 200

FL	PART NUMBER	shaft hole Ø mm	DIMENSIONS mm								bearing mm	housing No.	weight kg
			l	r	s	e	t	F	m	v			
203	93391203	17	113	90	65	11,4	26,5	11	33,7	15,4	M10	FL203	0,09
204	93391204	20	113	90	65	11,4	26,5	11	33,7	15,4	M10	FL204	0,09
205	93391203	25	131	99	69,5	13,5	29,1	11	36,7	17	M10	FL205	0,11
206	93391206	30	148	117	80	13,3	30,5	11	41,2	19	M10	FL206	0,13
207	93391207	35	164	130	90	16,1	32,8	13	43,4	18	M10	FL207	0,17
208	93391208	40	176	144	100	20	37,5	14	51,7	21,5	M10	FL208	0,24

SUCFL	PART NUMBER	shaft hole Ø mm	DIMENSIONS mm								bearing	housing No.	weight kg
			l	r	s	e	t	F	m	v			
206	93392206	30	148	117	80	13,3	30,5	11	41,2	19	SUC 206	FL206	0,44
207	93392207	35	164	130	90	16,1	32,8	13	43,4	18	SUC 207	FL207	0,63
208	93392208	40	176	144	100	20	37,5	14	51,7	21,5	SUC 208	FL208	0,85

CAD drawings available on our site
www.chiaravalli.com

Quantity, availability and prices
 on B2B Chiaravalli





FSB thermoplastic pillow blocks are planned for particular applications in the food industry, in the chemical, pharmaceutical and photographic industry; as well as where there are corrosion problems.

Thanks to the qualities of resistance to the corrosion and antimagnetism, they support hard work conditions in all their applications.

Thermoplastic FSB pillow blocks are planned and built with fat approved for food industry. (Contact us for requiring specific use fat).

Thermoplastic FSB pillow blocks are built to reply to the exigencies of:

- Resistance to corrosion
- Exposition to chemical agents
- Exposition to high damp percentages
- They can be oiled more than once
- They can operate at maximum temperatures between -35 °C and 120 °C.

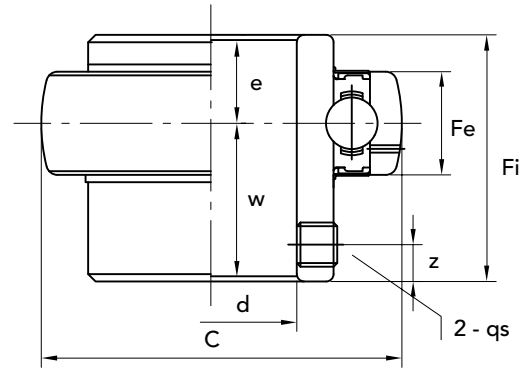
UC 200

UC	PART NUMBER	shaft hole Ø mm	DIMENSIONS mm							dynamic load N	static load N	weight kg
			C	Fi	Fe	e	w	z	qs			
201	93000201	12	47	31,0	17	12,7	18,3	4,8	M6x1,0	10000	6300	0,21
202	93000202	15	47	31,0	17	12,7	18,3	4,8	M6x1,0	10000	6300	0,19
203	93000203	17	47	31,0	17	12,7	18,3	4,8	M6x1,0	10000	6300	0,18
204	93000204	20	47	31,0	17	12,7	18,3	4,8	M6x1,0	10000	6300	0,16
205	93000205	25	52	34,0	17	14,3	19,7	5,5	M6x1,0	11000	7100	0,20
206	93000206	30	62	38,1	19	15,9	22,2	6,0	M6x1,0	15200	10200	0,32
207	93000207	35	72	42,9	20	17,5	25,4	6,5	M8x1,0	20100	13900	0,48
208	93000208	40	80	49,2	21	19,0	30,2	8,0	M8x1,0	25600	18100	0,64
209	93000209	45	85	49,2	22	19,0	30,2	8,0	M8x1,0	25600	18100	0,68
210	93000210	50	90	51,6	24	19,0	32,6	10	M10x1,0	27500	20200	0,82
211	93000211	55	100	55,6	25	22,2	33,4	10	M10x1,0	34000	25500	1,11
212	93000212	60	110	65,1	27	25,4	39,7	10	M10x1,0	41000	31500	1,54
213	93000213	65	120	65,1	28	25,4	39,7	10	M10x1,0	44800	34700	1,86
214	93000214	70	125	74,6	30	30,2	44,4	12	M12x1,5	48700	38100	2,06
215	93000215	75	130	77,8	30	33,3	44,5	12	M12x1,5	51900	41900	2,21
216	93000216	80	140	82,6	33	33,3	49,3	14	M12x1,5	57000	45500	2,79
217	93000217	85	150	85,7	35	34,1	51,6	14	M12x1,5	66000	53200	3,45
218	93000218	90	160	96,0	37	39,7	56,3	14	M12x1,5	75000	61700	4,35



CAD drawings available on our site
www.chiaravalli.com

Quantity, availability and prices
 on B2B Chiaravalli



UK 200

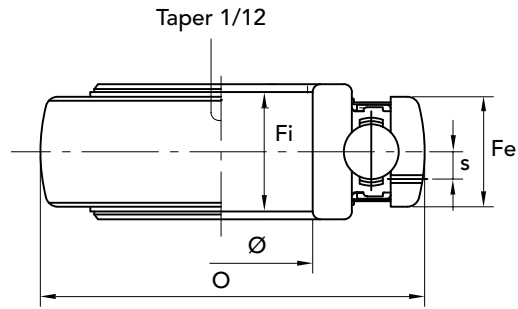

UK	PART NUMBER	shaft hole Ø mm	DIMENSIONS mm					dynamic load N	static load N	weight kg
			O	Fi	Fe	Fi (taper)	s			
207	93010207	30	72	28	20	30	5,9	20300	14000	0,37
208	93010208	35	80	29	21	34	6,2	23000	16000	0,47
209	93010209	40	85	31	22	36	6,6	25700	18100	0,52
210	93010210	45	90	31	24	36	6,5	27600	20100	0,59
211	93010211	50	100	34	25	40	7,0	34000	25500	0,80
212	93010212	55	110	36	27	47	7,6	41000	31500	1,02

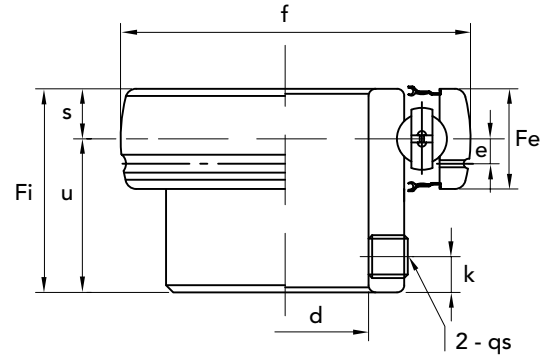

SB RE-LUBRICATING 200

SB	PART NUMBER	shaft hole Ø mm	DIMENSIONS mm								dynamic load N	static load N	weight kg
			Fe	f	F1	s	u	k	e	qs			
201	93020201	12	12	40	22	6,0	16,0	4,5	3,6	M5x0,8	7600	4500	0,10
202	93020202	15	12	40	22	6,0	16,0	4,5	3,6	M5x0,8	7600	4500	0,10
203	93020203	17	12	40	22	6,0	16,0	4,5	3,6	M5x0,8	7600	4500	0,10
204	93020204	20	14	47	25	7,0	18,0	4,5	3,9	M6x1,0	10000	6300	0,15
205	93020205	25	15	52	27	7,5	19,5	5,5	3,9	M6x1,0	11000	7100	0,18
206	93020206	30	16	62	30	8,0	22,0	5,5	5,0	M6x1,0	15200	10200	0,27
207	93020207	35	17	72	32	8,5	23,5	6,5	5,5	M8x1,0	20100	13900	0,42
208	93020208	40	18	80	34	9,0	25,0	7,0	6,0	M8x1,0	25600	18100	0,60
209	93020209	45	19	85	41,2	9,5	31,7	8,2	6,3	M8x1,0	32600	24500	0,80
210	93020210	50	20	90	41,6	10,0	31,6	9,2	6,5	M8x1,0	35800	23000	0,83

CAD drawings available on our site
www.chiaravalli.com

Quantity, availability and prices
 on B2B Chiaravalli





SA RE-LUBRICATING 200

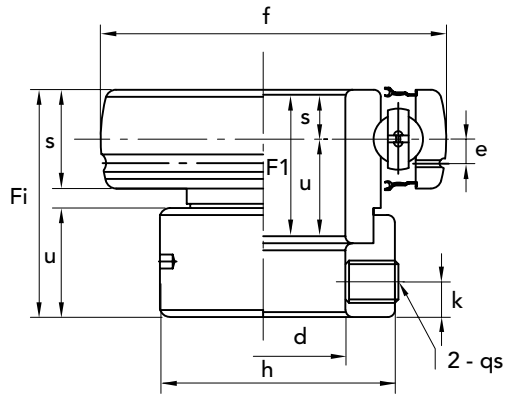

SA	PART NUMBER	shaft hole Ø mm	DIMENSIONS mm											dynamic load N	static load N	weight kg
			Fe	f	F1	s	u	Fi	h	o	k	e	qs			
201	93030201	12	12	40	19,1	6,0	13,1	28,6	28,6	13,5	5,0	3,6	M6x1,0	9600	4800	0,13
202	93030202	15	12	40	19,1	6,0	13,1	28,6	28,6	13,5	5,0	3,6	M6x1,0	9600	4800	0,13
203	93030203	17	12	40	19,1	6,0	13,1	28,6	28,6	13,5	5,0	3,6	M6x1,0	9600	4800	0,13
204	93030204	20	14	47	21,5	7,0	14,5	31,0	33,3	13,5	5,0	3,9	M6x1,0	10000	6300	0,15
205	93030205	25	15	52	21,5	7,5	14	31,0	38,1	13,5	5,0	3,9	M6x1,0	11000	7100	0,22
206	93030206	30	16	62	23,8	8,0	15,8	35,7	44,5	15,9	6,0	5	M8x1,0	15200	10200	0,30
207	93030207	35	17	72	25,4	8,5	16,9	38,9	55,6	17,5	6,5	5,5	M8x1,0	20100	13900	0,50
208	93030208	40	18	80	30,2	9,0	21,2	43,7	60,3	18,3	6,5	6,0	M8x1,0	25600	18100	0,67
209	93030209	45	19	85	30,2	9,5	20,7	43,7	63,5	18,3	6,5	6,3	M8x1,0	33000	21000	0,73
210	93030210	50	20	90	30,2	10,0	20,2	43,7	69,9	18,3	6,5	6,5	M8x1,0	35000	23000	0,83

BALL BEARINGS SERIES SA RE-LUBRICATING 200

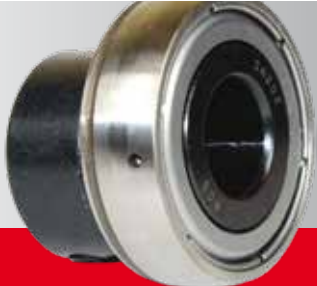

CAD drawings available on our site
www.chiaravalli.com

Quantity, availability and prices
 on B2B Chiaravalli



USING TEMPERATURES AND MATERIALS

Description	Materials
Frame	AISI 304
Grubscrew	AISI 304
Cage	AISI 321
Ring and frame	AISI 321
Internal and external ring	AISI 440C
Ball	AISI 404C
Nipple	AISI 302
Operating temperature	-20° +120°

Clamping torque

GRUBSCREW	Bearing n°	Clamping torque (N//m)
M6 X 1	SUC 204-206	3,9
M8 X 1	SUC 207-209	8,3
M10 X 1	SUC 210	16

TYPICAL APPLICATIONS

Machines for food, pharmaceutical, Chemical and agricultural Industry...

Where rustproofing and anticorrosion features are required.



SUC 200

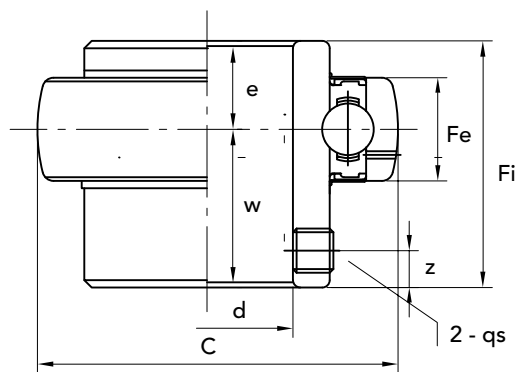

INOX BALL BEARINGS SERIES SUC 200

SUC	PART NUMBER	shaft hole Ø mm	DIMENSIONS mm							dynamic load N	static load N	weight kg
			C	Fi	Fe	e	w	z	qs			
203	93009203	17	47	31,0	17	12,7	18,3	4,8	M6x1,0	10000	6300	0,18
204	93009204	20	47	31,0	17	12,7	18,3	4,8	M6x1,0	10000	6300	0,16
205	93009205	25	52	34,0	17	14,3	19,7	5,5	M6x1,0	11000	7100	0,20
206	93009206	30	62	38,1	19	15,9	22,2	6,0	M6x1,0	15200	10200	0,32
207	93009207	35	72	42,9	20	17,5	25,4	6,5	M8x1,0	20100	13900	0,48
208	93009208	40	80	49,2	21	19,0	30,2	8,0	M8x1,0	25600	18100	0,64
209	93009209	45	85	49,2	22	19,0	30,2	8,0	M8x1,0	25600	18100	0,68
210	93009210	50	90	51,6	24	19,0	32,6	10	M10x1,0	27500	20200	0,82





INOX BALL BEARINGS SERIES SSSB RE-LUBRICATING 200

SSSB RE-LUBRICATING 200

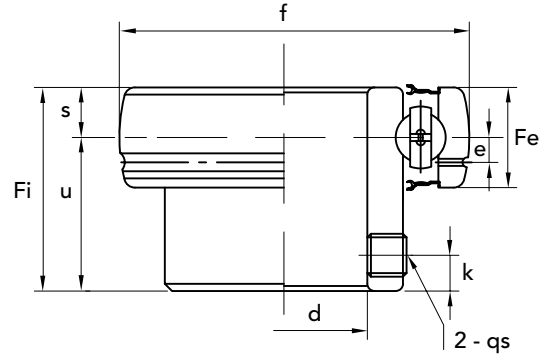

SSSB	PART NUMBER	shaft hole Ø mm	DIMENSIONS mm								dynamic load N	static load N	weight kg
			Fe	f	F1	s	u	k	e	qs			
203	93029203	17	12	40	22	6,0	16,0	4,5	3,6	M5x0,8	7600	4500	0,10
204	93029204	20	14	47	25	7,0	18,0	4,5	3,9	M6x1,0	10000	6300	0,15
205	93029205	25	15	52	27	7,5	19,5	5,5	3,9	M6x1,0	11000	7100	0,18
206	93029206	30	16	62	30	8,0	22,0	5,5	5,0	M6x1,0	15200	10200	0,27
207	93029207	35	17	72	32	8,5	23,5	6,5	5,5	M8x1,0	20100	13900	0,42
208	93029208	40	18	80	34	9,0	25,0	7,0	6,0	M8x1,0	25600	18100	0,60
209	93029209	45	19	85	41,2	9,5	31,7	8,2	6,3	M8x1,0	32600	24500	0,80
210	93029210	50	20	90	41,6	10,0	31,6	9,2	6,5	M8x1,0	35800	23000	0,83



CAD drawings available on our site
www.chiaravalli.com

Quantity, availability and prices
on B2B Chiaravalli



BUSHES SERIES H23...

H	PART NUMBER	Shaft hole Ø mm
2307	93002307	30
2308	93002308	35
2309	93002309	40
2310	93002310	45
2311	93002311	50
2312	93002312	55



COVERS FOR CAST IRON PILLOW BLOCKS

CLOSED COVERS

OPEN COVERS WITH GASKET



for pillow block	PART NUMBER
202	93320202
203	93320203
204	93320204
205	93320205
206	93320206
207	93320207
208	93320208
209	93320209
210	93320210
211	93320211



for pillow block	PART NUMBER
202	93330202
203	93330203
204	93330204
205	93330205
206	93330206
207	93330207
208	93330208
209	93330209
210	93330210
211	93330211

COVERS FOR PRESSED STEEL HOUSING AND THERMOPLASTIC PILLOW BLOCKS

CLOSED COVERS

OPEN COVERS WITH GASKET



for pillow block	PART NUMBER
202	93329202
203	93329203
204	93329204
205	93329205
206	93329206
207	93329207
208	93329208
209	93329209
210	93329210
211	93329211



for pillow block	PART NUMBER
203	93339203
204	93339204
205	93339205
206	93339206
207	93339207
208	93339208
209	93339209
210	93339210

BUSHES SERIES H23... COVERS FOR PILLOW BLOCKS



SERIE F - FL - P

for pillow block	d	PART NUMBER
BS203	17	93349203
BS204	20	93349204
BS205	25	93349205
BS206	30	93349206
BS207	35	93349207
BS208	40	93349208
BS209	45	93349209
BS210	50	93349210





RCC 2RS

PRODUCED BY COMPANY
CERTIFIED ISO 9001

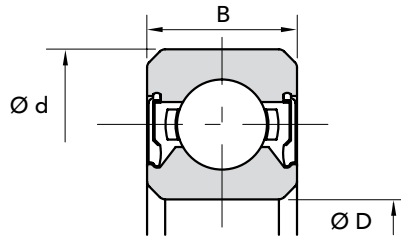

TYPE	PART NUMBER	D mm	d mm	B mm	dynamic load KN	static load KN	Weight Kg.
607 2RS	93060702	7	19	6	2,88	1,08	0,01
608 2RS	93060802	8	22	7	3,32	1,38	0,02
609 2RS	93060902	9	24	7	3,35	1,40	0,16
6000 2RS	93060002	10	26	8	4,58	1,98	0,02
6001 2RS	93060012	12	28	8	5,10	2,38	0,02
6002 2RS	93060022	15	32	9	5,58	2,85	0,03
6003 2RS	93060032	17	35	10	6,00	3,25	0,04
6004 2RS	93060042	20	42	12	9,38	5,02	0,07
6005 2RS	93060052	25	47	12	10,00	5,85	0,08
6006 2RS	93060062	30	55	13	13,20	8,30	0,12
6007 2RS	93060072	35	65	14	16,00	10,30	0,16
6008 2RS	93060082	40	68	15	16,80	11,50	0,20
6009 2RS	93060092	45	75	16	21,00	15,20	0,25
6010 2RS	93060102	50	80	16	21,80	16,60	0,29
6011 2RS	93060112	55	90	18	28,30	21,30	0,39
6012 2RS	93060122	60	95	18	29,50	23,20	0,42
6200 2RS	93062002	10	30	9	5,10	2,38	0,03
6201 2RS	93062012	12	32	10	6,82	3,05	0,04
6202 2RS	93062022	15	35	11	7,65	3,72	0,05
6203 2RS	93062032	17	40	12	9,58	4,78	0,07
6204 2RS	93062042	20	47	14	12,80	6,56	0,10
6205 2RS	93062052	25	52	15	14,00	7,88	0,12
6206 2RS	93062062	30	62	16	19,50	11,30	0,20
6207 2RS	93062072	35	72	17	25,70	15,30	0,29
6208 2RS	93062082	40	80	18	29,10	17,90	0,37
6209 2RS	93062092	45	85	19	32,50	20,50	0,41
6210 2RS	93062102	50	90	20	35,00	23,20	0,46
6211 2RS	93062112	55	100	21	43,50	29,30	0,61
6212 2RS	93062122	60	110	22	52,50	36,00	0,79
6213 2RS	93062132	65	120	23	54,00	38,00	0,90
6214 2RS	93062142	70	125	24	60,20	42,30	0,98
6300 2RS	93063002	10	35	11	7,65	3,48	0,06
6301 2RS	93063012	12	37	12	9,72	5,08	0,06
6302 2RS	93063022	15	42	13	11,50	5,42	0,08
6303 2RS	93063032	17	47	14	13,50	6,58	0,11
6304 2RS	93063042	20	52	15	15,80	7,88	0,14
6305 2RS	93063052	25	62	17	22,20	11,50	0,22
6306 2RS	93063062	30	72	19	27,00	15,20	0,35
6307 2RS	93063072	35	80	21	33,40	19,20	0,46
6308 2RS	93063082	40	90	23	40,80	24,00	0,64
6309 2RS	93063092	45	100	25	52,50	31,80	0,84
6310 2RS	93063102	50	110	27	61,80	38,00	1,09
6311 2RS	93063112	55	120	29	71,50	44,80	1,37
6312 2RS	93063122	60	130	31	81,80	51,80	1,71
6313 2RS	93063132	65	140	33	93,80	60,50	2,10
6314 2RS	93063142	70	150	35	105,00	58,00	2,55
6315 2RS	93063152	75	160	37	113,00	76,80	3,05



MONOBLOCK PILLOW BLOCKS RCM[®] BRAND

PILLOW BLOCKS

RCM SERIES	page 30
Nominal torque and power rating	33
Diagram for the choice of RCM pillow blocks	34
RCM SERIES AS standard shaft	36
RCM SERIES AL long shaft	38
RCM SERIES RCM-AL for cooling fan	40
NON-ROTATING GROUP	41



MONOBLOCK PILLOW BLOCKS BRAND RCM®

RCM - AS Standard shaft

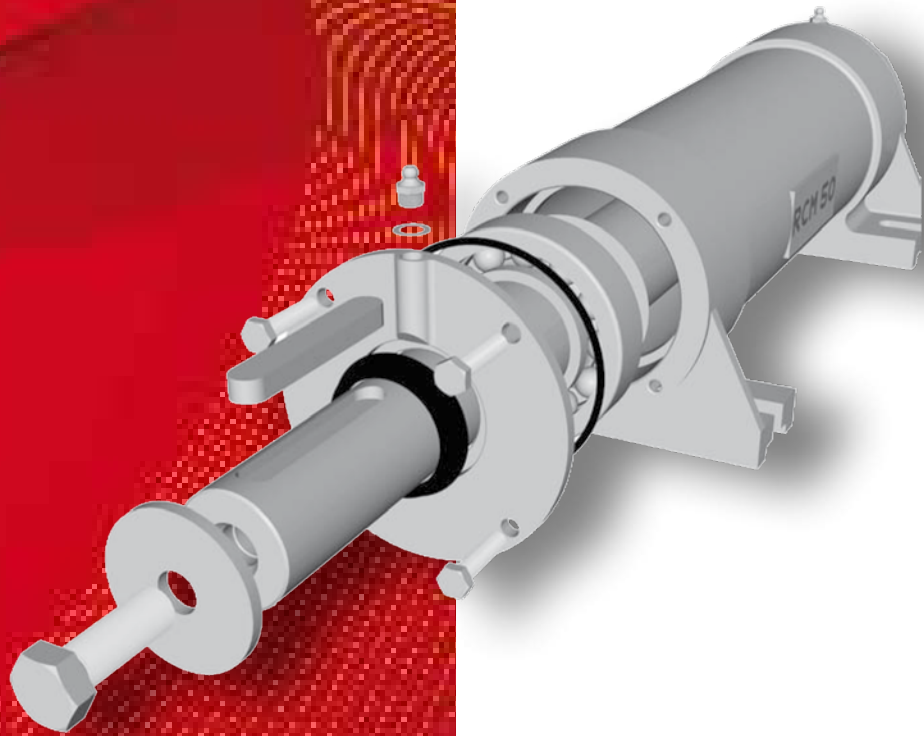
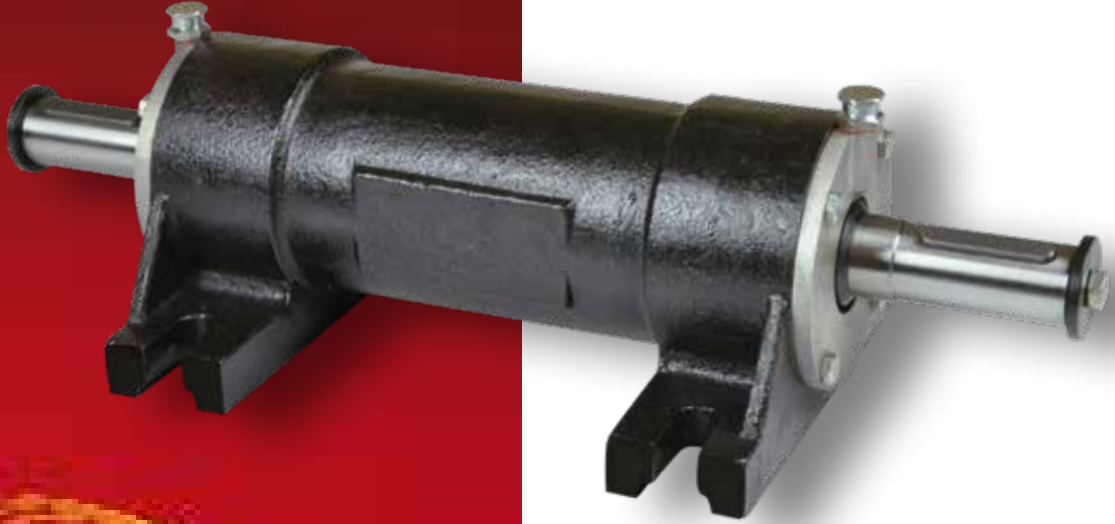



RCM - AL
Long shaft

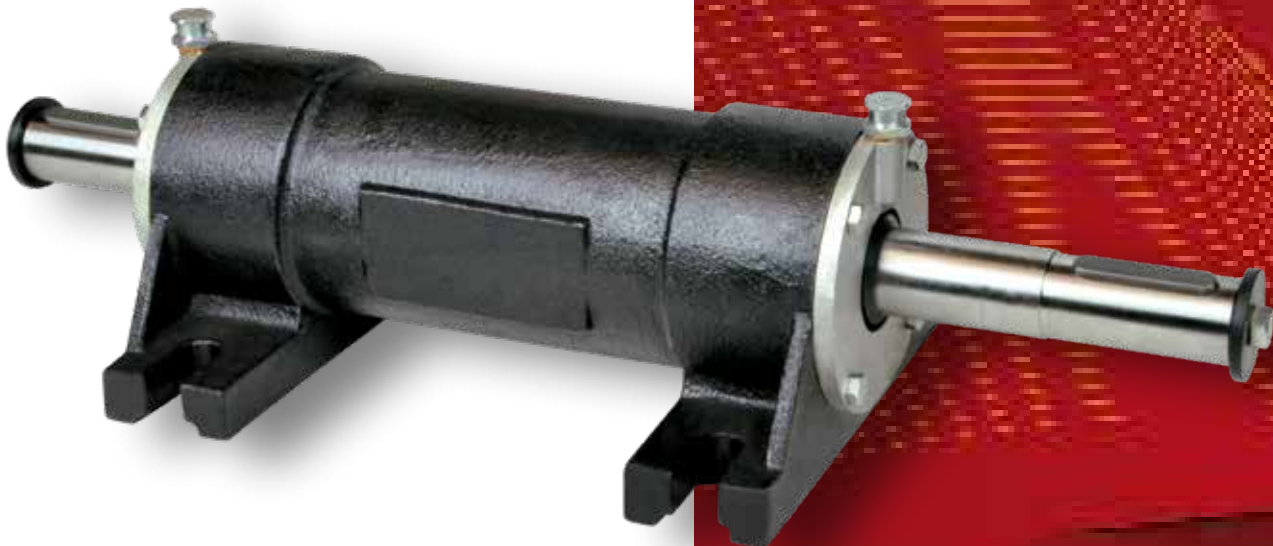

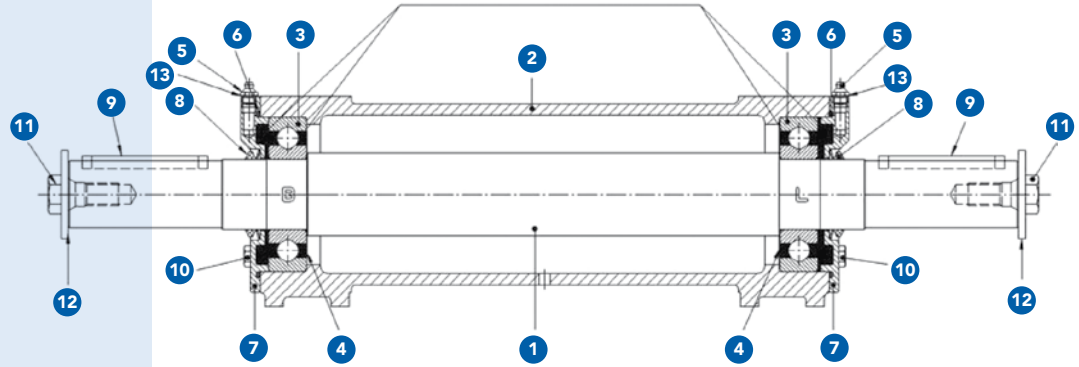

DESCRIPTION

- 1 Steel shaft
- 2 Casing cast iron
- 3 Bearing series 63XX
- 4 Disc retainer
- 5 Galvanized grease
- 6 Seal OR
- 7 Cover
- 8 Ring V-ring
- 9 Key
- 10 Cover zinc screw
- 11 Head zinc screw
- 12 Head washer
- 13 Copper washer

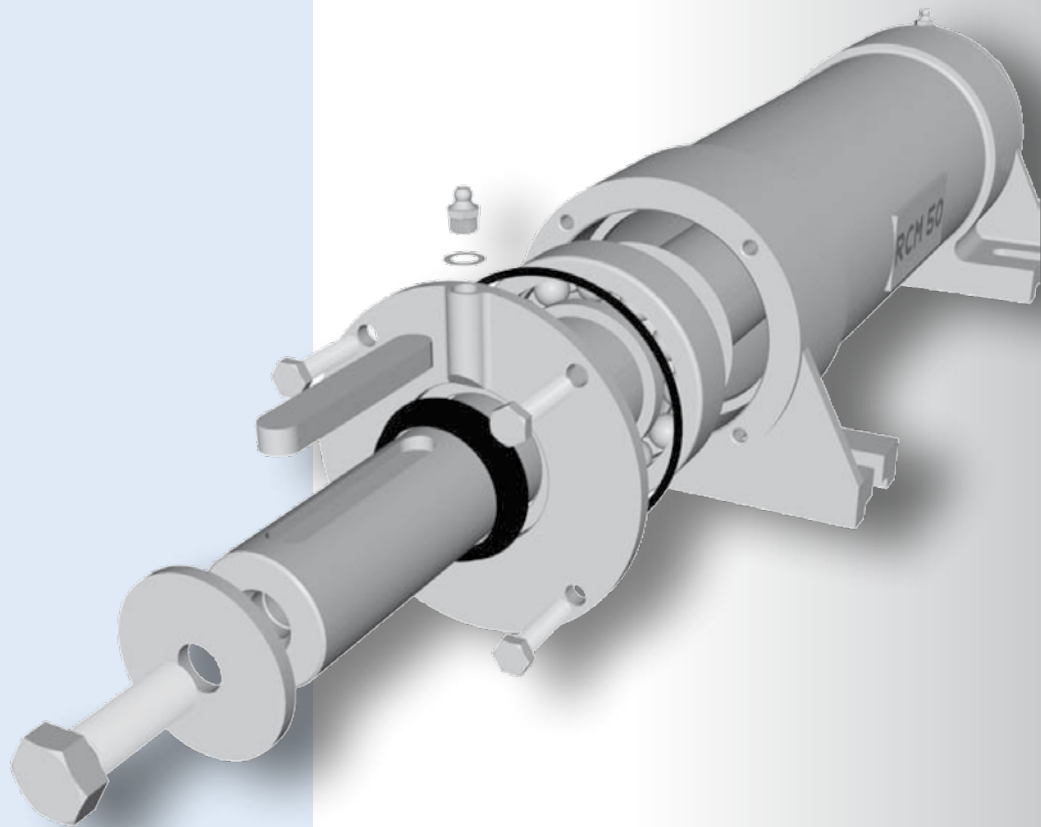

Fill with grease L G M T - 2 S K F





SELECTION CRITERIA OF PILLOWS BLOCKS

The choice of the pillow block is carried out by the curves of power if, the motor type is applied directly, or a gearbox equip the motor.

The maximum output values of the powers and torques are calculated with service factor $F_s=1$

These values must therefore be adapted to the needs and safety criteria of 'user.

THREE-PHASE ASYNCHRONOUS CAGE MOTOR - POWERS IN ACCORDANCE WITH REGULATIONS IEC-72

TYPE	Maximum torque (Nm)	Power with 8 motor poles turns/min. 750 (KW)	Power with 6 motor poles turns/min. 1000 (KW)	Power with 4 motor poles turns/min. 1500 (KW)	Power with 2 motor poles turns/min. 3000 (KW)
RCM 25	16	1,1	1,5	2,2	4,5
RCM 30	28	2,2	3	4,5	9
RCM 35	56	4	5,5	7,5	15
RCM 40	70	5,5	7,5	11	22
RCM 45	125	9,5	11	18,5	37
RCM 50	200	15	18,5	30	55
RCM 55	240	18,5	22	37	75
RCM 60	380	30	37	55	110
RCM 65	480	37	45	75	132
RCM 70	600	45	55	90	160
RCM 75	1000	75	90	132	250
RCM 80	1300	90	132	200	375

PILLOW BLOCKS BRAND RCM® NOMINAL TORQUE AND DRIVING POWER

PLEASE NOTE:

All data and performance are listed in the catalogue for safety factor $F_s=1$

CAD drawings available on our site
www.chiaravalli.com

Quantity, availability and prices on B2B Chiaravalli



DIAGRAM FOR THE CHOICE OF PILLOW BLOCKS RCM

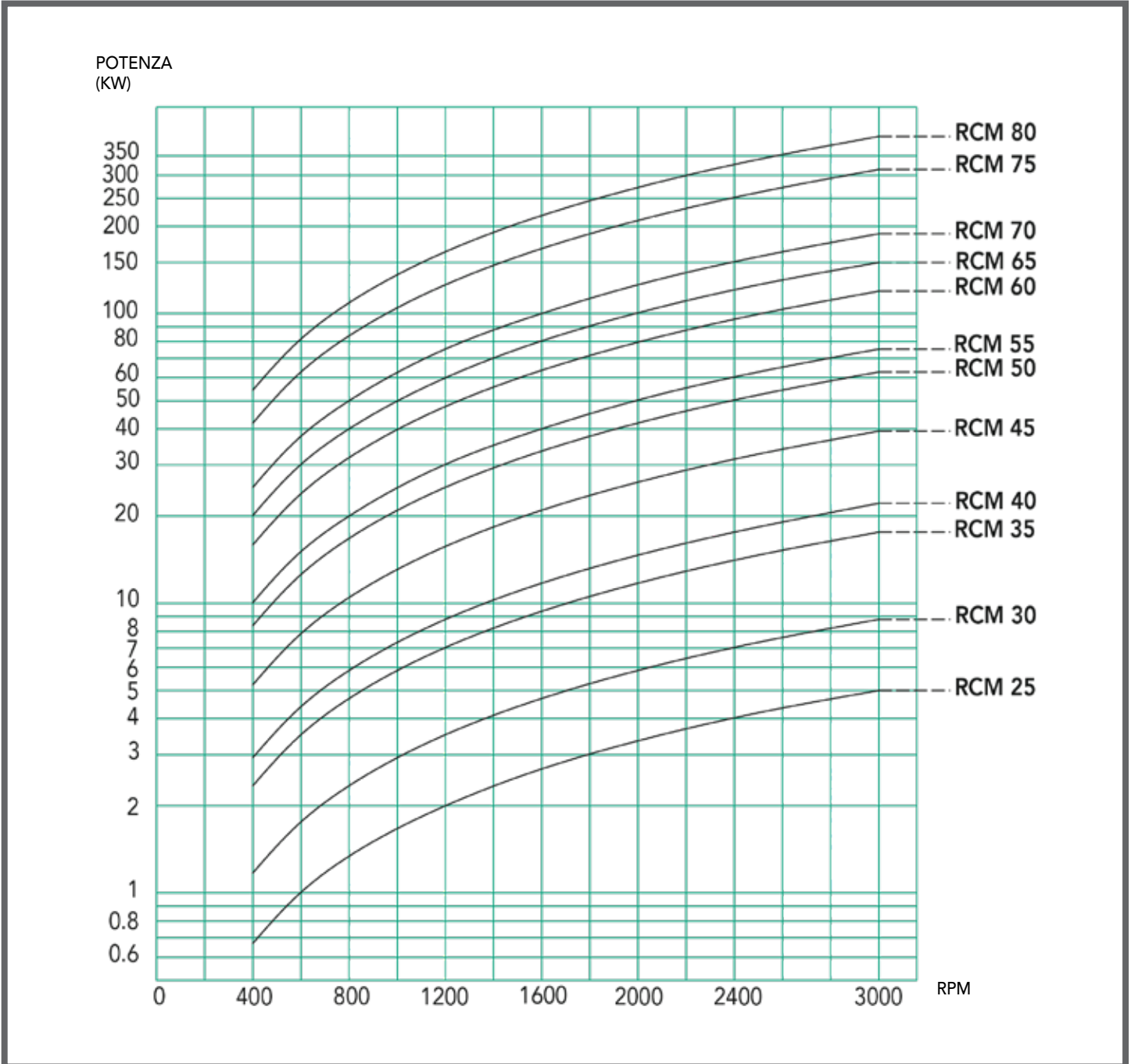

PLEASE NOTE:

All data and performance are listed in the catalogue for safety factor $F_s=1$

CAD drawings available on our site
www.chiaravalli.com

Quantity, availability and prices
 on B2B Chiaravalli



ALLOWABLE LOAD ON THE SHAFT "LOCKED" SIDE DEPENDING ON THE SHAFT OPERATION SPEED

If the connection between the drive motor and the support block, or between the support and the user is carried out by means which generate radial loads on the shaft end, you should verify that these loads are less than the allowable loads shown in the below graph. The maximum radial loads shown in the graphs are calculated with service factor $F_s=1$ and apply to an application point at "x" distance from the shaft.

For radial loads applied at a distance greater than and equal to $1.5x$, the value indicated by the graphs must be multiplied by an adjustment factor equal to 0.67

Even the radial loads must be adapted to the specific needs and safety criteria chosen by the user.

ALLOWABLE LOAD ON THE SHAFT "LOCKED" SIDE DEPENDING ON THE SHAFT OPERATION SPEED

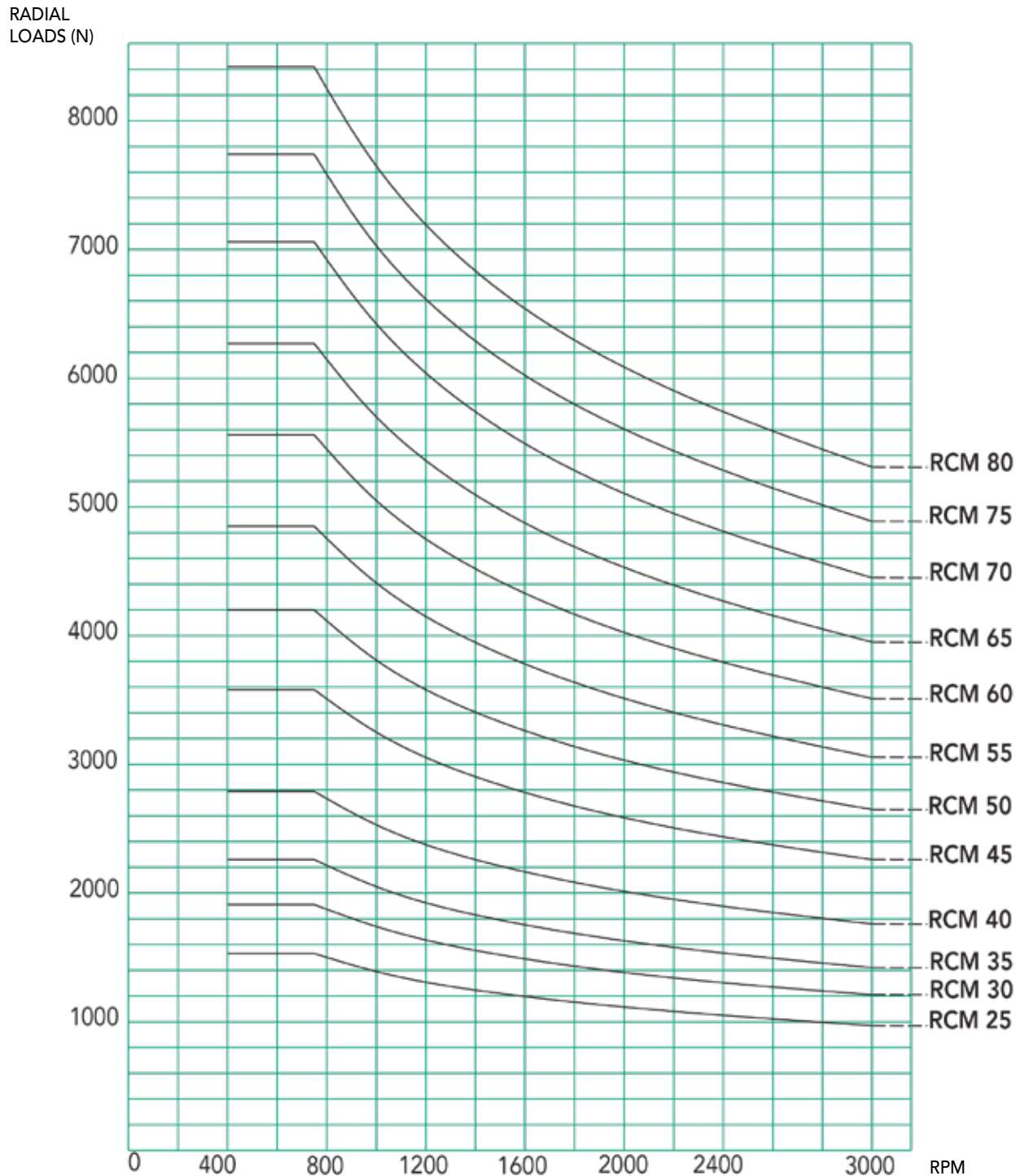

PLEASE NOTE:

All data and performance are listed in the catalogue for safety factor $F_s=1$

CAD drawings available on our site www.chiaravalli.com

Quantity, availability and prices on B2B Chiaravalli



For models
AS 45 - 50 - 55 - 60 - 70 - 75 - 80
can be supplied a non-rotating group
EUROPEAN PATENT N° 03425164.5
fitted in place of the side cover
locked bearing (b)

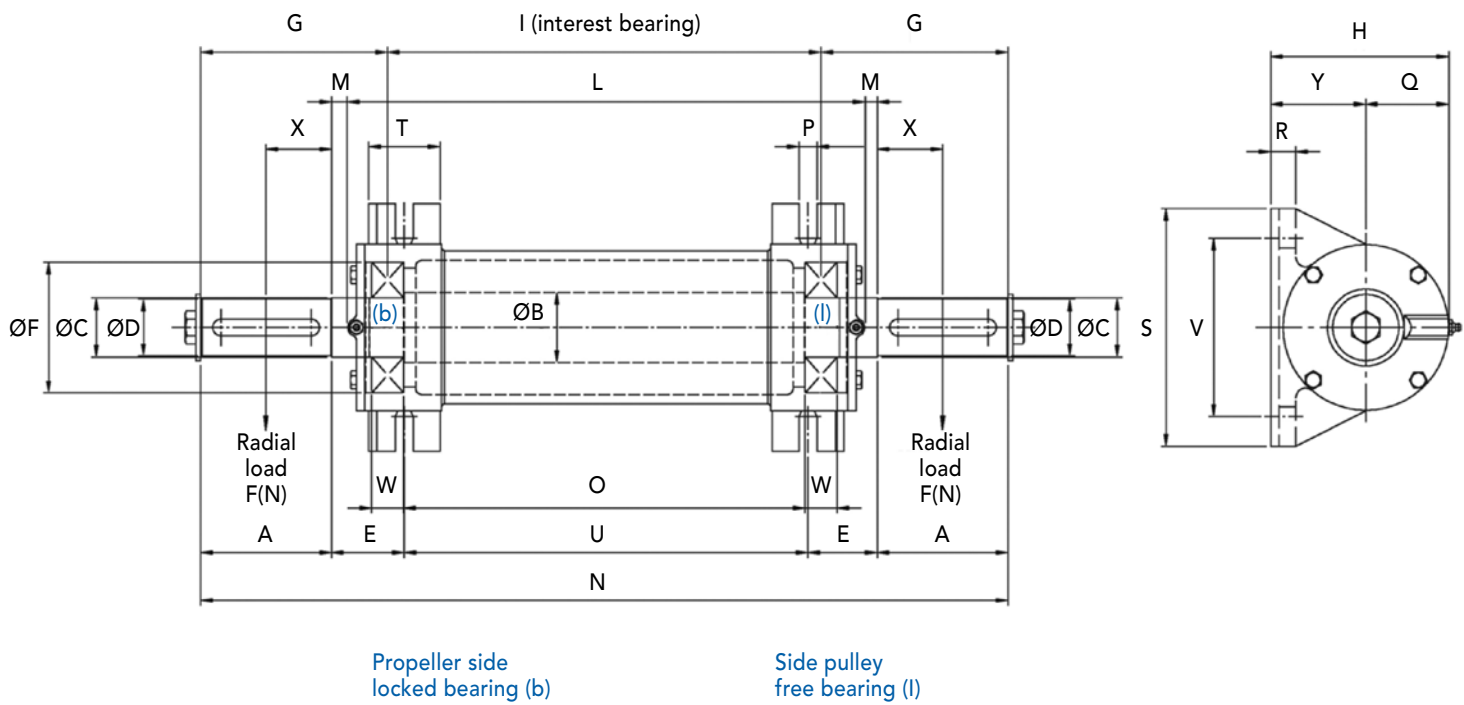



For models
AS 45 - 50 - 55 - 60 - 70 - 75 - 80
can be supplied a non-rotating group
EUROPEAN PATENT N° 03425164.5
fitted in place of the side cover
locked bearing (b)

TYPE	P. NUMBER	ØD	A	E	L	U	ØF	P	T	ØB	N	G	I	O	ØC	Q	H	R	V	S	Y	W	M	X
25	95000251	24j6	50	50	281	200	62	15	50	34	400	88,5	222	205	25	45	105	20	135	180	60	17	9,5	25
30	95000301	28j6	60	50	281	200	72	15	50	39	420	99,5	220	201	30	50	110	20	135	180	60	19	9,5	30
35	95000351	32k6	60	56	352	265	80	15	50	43	497	103,5	288	267	35	54	124	20	145	195	70	21	12,5	30
40	95000401	38k6	80	56	351	265	90	15	50	48	537	125	286	263	40	58	128	20	145	195	70	23	13	40
45	95000451	42k6	110	60	434	340	100	15	60	53	680	156	367	342	45	70	150	20	150	200	80	25	13	55
50	95000501	48k6	110	60	435	340	110	15	60	59	680	156,5	366	339	50	70	150	20	150	200	80	27	12,5	55
55	95000551	48k6	110	86	571	448	120	18	80	64	840	169,5	500	471	55	75	165	24	180	230	90	29	24,5	55
60	95000601	55m6	110	86	570	448	130	18	80	71	840	171	497	466	60	85	175	24	180	230	90	31	25	55
65	95000651	60m6	140	75	574	448	140	20	90	76	878	191	495	462	65	84	184	24	190	250	100	33	12	70
70	95000701	65m6	140	75	574	448	150	20	90	81	878	192	492	457	70	90	190	24	190	250	100	35	12	70
75	95000751	70m6	150	80	594	460	160	22	100	86	930	209	511	474	75	102	202	28	280	355	100	37	18	75
80	95000801	75m6	150	85	598	460	170	22	100	91	930	210	509	470	80	102	202	28	280	355	100	39	16	75

TYPE	P. NUMBER	Bearing	Head screw	Head washer	Key	Weight kg.
25	95000251	6305	M8	8,5 x 36 x 4	8 x 7 x 35	8
30	95000301	6306	M8	8,5 x 36 x 4	8 x 7 x 45	10
35	95000351	6307	M12	12,5 x 48 x 4	10 x 8 x 45	14
40	95000401	6308	M12	12,5 x 48 x 4	10 x 8 x 60	17
45	95000451	6309	M16	16,5 x 63 x 5	12 x 8 x 90	24
50	95000501	6310	M16	16,5 x 63 x 5	14 x 9 x 90	28
55	95000551	6311	M16	16,5 x 85 x 6	14 x 9 x 90	43
60	95000601	6312	M16	16,5 x 85 x 6	16 x 10 x 90	49
65	95000651	6313	M16	16,5 x 85 x 6	18 x 11 x 120	56
70	95000701	6314	M16	16,5 x 85 x 6	18 x 11 x 120	61
75	95000751	6315	M20	20,5 x 100 x 8	20 x 12 x 130	89
80	95000801	6316	M20	20,5 x 100 x 8	20 x 12 x 130	90



For models
AS 45 - 50 - 55 - 60
can be supplied a non-rotating group
EUROPEAN PATENT N° 03425164.5
fitted in place of the side cover
locked bearing (b)

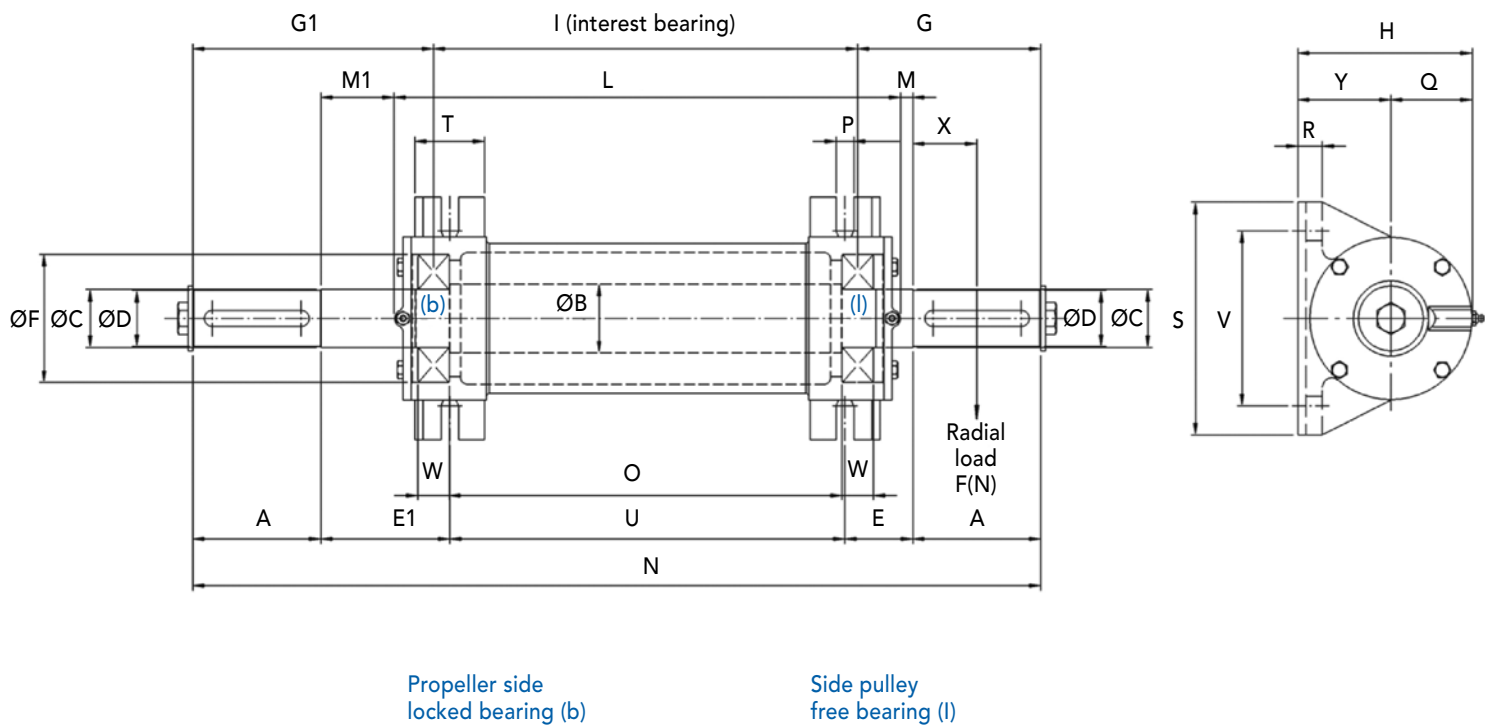



For models
AS 45 - 50 - 55 - 60
can be supplied a non-rotating group
EUROPEAN PATENT N° 03425164.5
fitted in place of the side cover
locked bearing (b)

TYPE	P. NUMBER	ØD	A	E	E1	L	U	ØF	P	T	ØB	N	G	G1	I	O	ØC	Q	H	R	V	S	Y	W	M	X	G1
30	95000302	28j6	60	50	90	281	200	72	15	50	39	460	99,5	139,5	220	201	30	50	110	20	135	180	60	19	9,5	30	49,5
35	95000352	32k6	60	56	100	352	265	80	15	50	43	541	103,5	147,5	288	267	35	54	124	20	145	195	70	21	12,5	30	56,5
40	95000402	38k6	80	56	110	351	265	90	15	50	48	591	125	179	286	263	40	58	128	20	145	195	70	23	13	40	67
45	95000452	42k6	110	60	110	434	340	100	15	60	53	730	156	206	367	342	45	70	150	20	150	200	80	25	13	55	63
50	95000502	48k6	110	60	110	435	340	110	15	60	59	730	156,5	206,5	366	339	50	70	150	20	150	200	80	27	12,5	55	62,5
55	95000552	48k6	110	86	140	571	448	120	18	80	64	894	169,5	223,5	500	471	55	75	165	24	180	230	90	29	24,5	55	78,5
60	95000602	55m6	110	86	140	570	448	130	18	80	71	894	171	225	497	466	60	85	175	24	180	230	90	31	25	55	79
65	95000652	60m6	140	86	140	574	443	140	20	90	76	955	203	257	495	462	65	84	184	24	190	250	100	33	23,5	70	77,5

TYPE	P. NUMBER	Bearing	Head screw	Head washer	Keyway	Weight kg.
30	95000302	6306	M8	8,5 x 36 x 4	8 x 7 x 45	10
35	95000352	6307	M12	12,5 x 48 x 4	10 x 8 x 45	14
40	95000402	6308	M12	12,5 x 48 x 4	10 x 8 x 60	17
45	95000452	6309	M16	16,5 x 63 x 5	12 x 8 x 90	24
50	95000502	6310	M16	16,5 x 63 x 5	14 x 9 x 90	28
55	95000552	6311	M16	16,5 x 85 x 6	14 x 9 x 90	43
60	95000602	6312	M16	16,5 x 85 x 6	16 x 10 x 90	49
65	95000652	6313	M16	16,5 x 85 x 6	18 x 11 x 120	58



RCM-AL FOR COOLING FAN

TYPE	PART NUMBER	A	B	C
30	95000303	115	28	29,8
35	95000353	135	30	34,8
40	95000403	135	30	39,8
45	95000453	155	32	44,8
50	95000503	155	32	49,8
55	95000553	170	32	54,8
60	95000603	170	32	59,8
65	95000653	188	30	64,8

TYPE	PART NUMBER
30	95000001
35-40	95000002
45-50	95000003
55-60	95000004

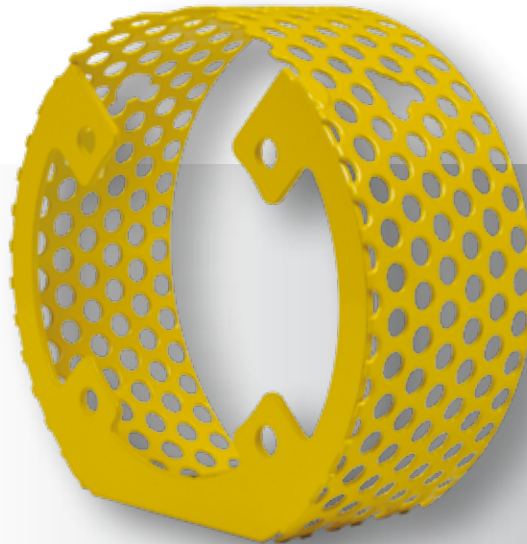
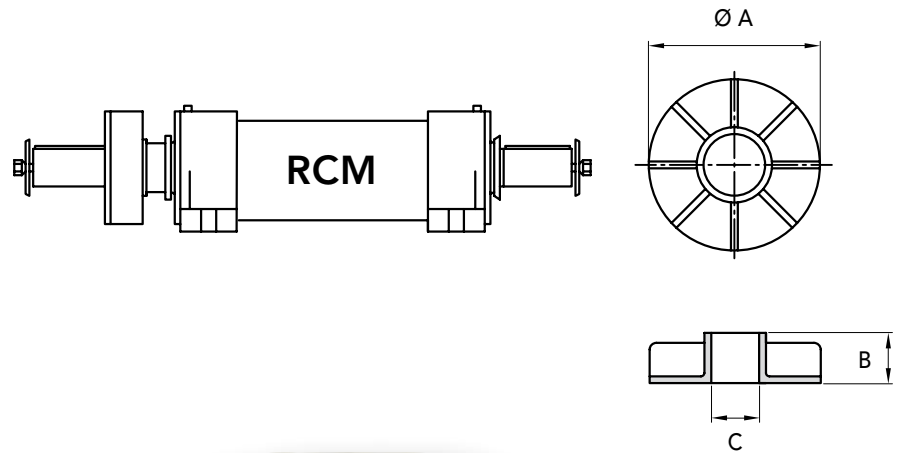

FAN PROTECTION



FAN



RCM-AS Models with non-rotating group

Type	PART NUMBER	max RPM without load n°/1'
45	95000045	500
50	95000050	475
55	95000055	400
60	95000060	350
65	95000065	350
70	95000070	330
75	95000075	325
80	95000080	300

RCM-AL Models with non-rotating group

Type	PART NUMBER	max RPM without load n°/1'
45	95000045	500
50	95000050	475
55	95000055	400
60	95000060	350
65	95000065	350

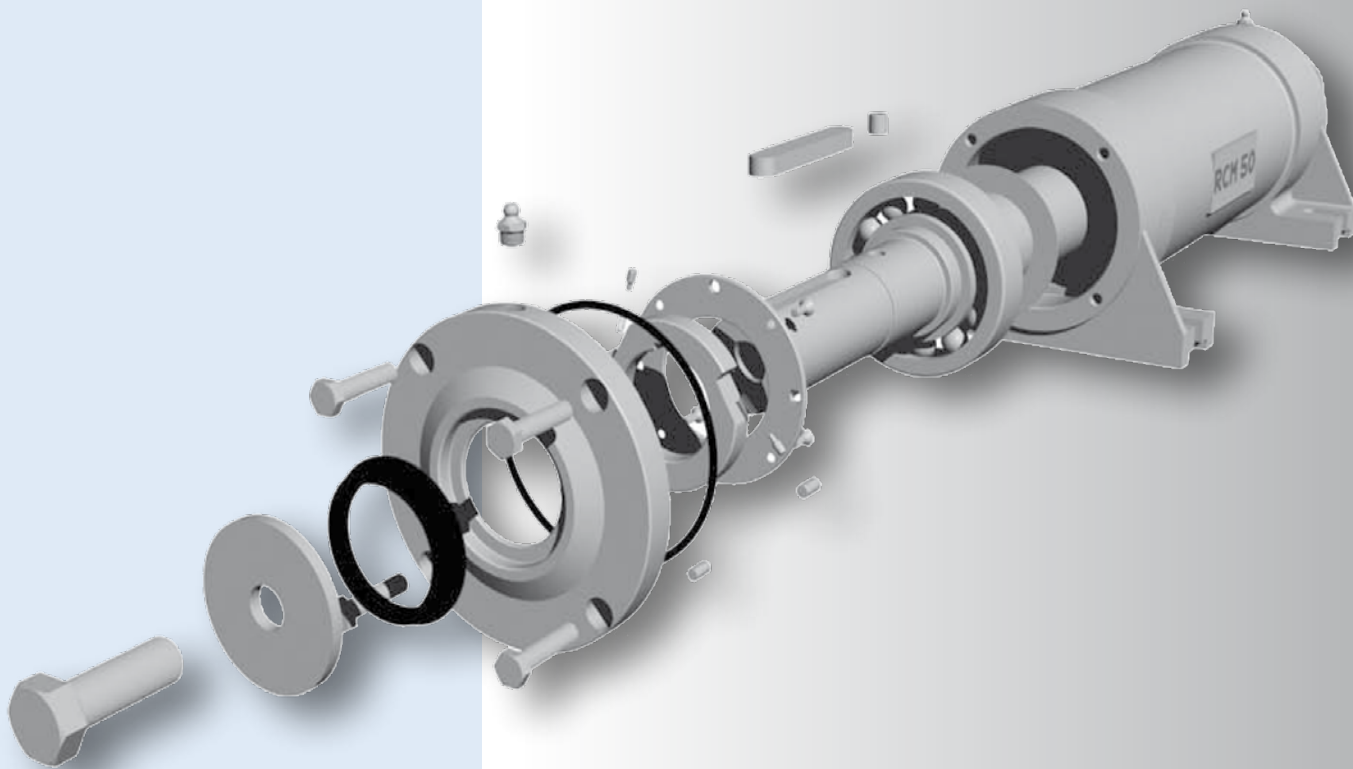

EUROPEAN PATENT N° 03425164.5

PILLOW BLOCKS BRAND RCM® NON-ROTATING GROUP